

REVISIONS:

# A PORTION OF SEC 27, TWP 19 N., RGE 28 E., W.M. GRANT COUNTY, WASHINGTON

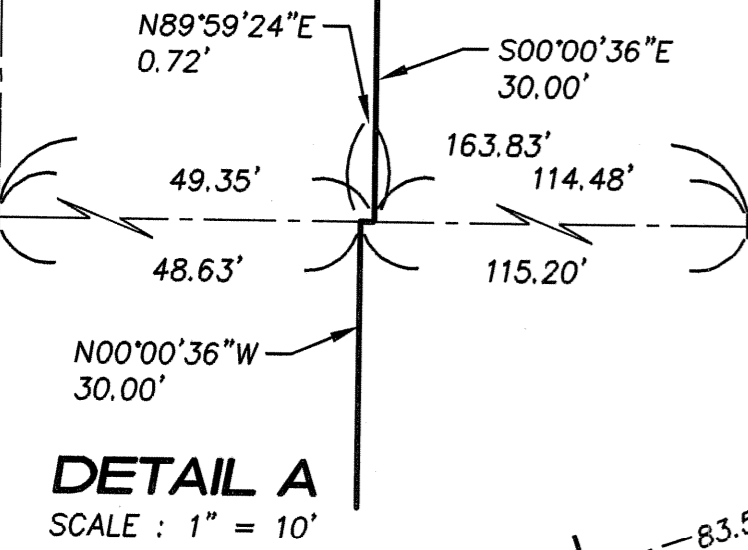

CURVE	DELTA	RADIUS	LENGTH	TANGENT
C22	6°10'31"	460.00'	49.58'	24.81'
C23	8°37'27"	460.00'	69.24'	34.69'
C24	8°10'58"	460.00'	65.69'	32.90'
C25	87°37'36"	20.00'	30.59'	19.19'
C26	87°19'33"	20.00'	30.48'	19.09'
C27	10°27'11"	400.00'	72.98'	36.59'
C28	11°42'48"	400.00'	81.77'	41.03'
C29	11°42'48"	400.00'	81.77'	41.03'
C30	3°36'53"	1216.34'	76.74'	38.38'

CURVE	DELTA	RADIUS	LENGTH	TANGENT
C31	7°25'25"	1216.34'	157.60'	78.91'
C32	88°05'44"	20.00'	30.75'	19.35'
C33	3°58'02"	256.48'	17.76'	8.88'
C34	14°23'01"	256.48'	64.39'	32.36'
C35	16°06'41"	20.00'	5.62'	2.83'
C36	40°40'47"	20.00'	14.20'	7.41'
C37	87°33'28"	40.00'	61.13'	38.33'
C38	44°29'21"	40.00'	31.06'	16.36'
C39	10°21'42"	40.00'	7.23'	3.63'
C40	29°02'09"	276.48'	140.11'	71.59'

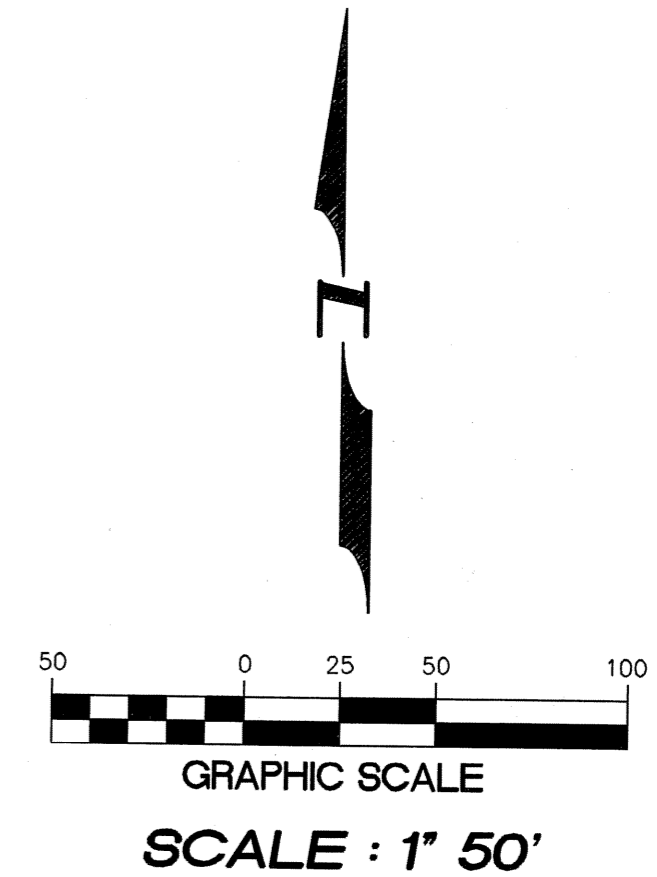
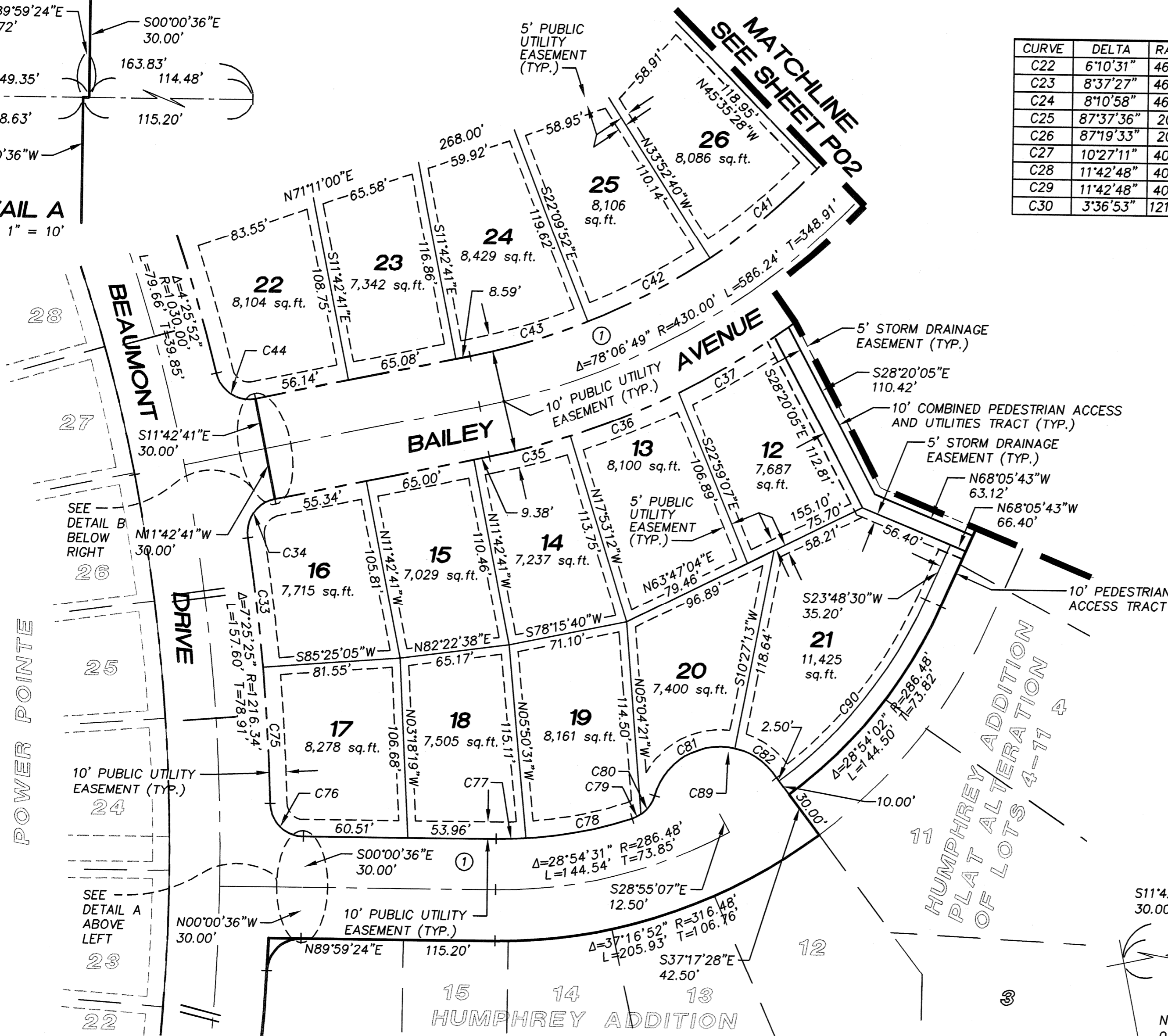

**NOTE**  
① ROAD RIGHT-OF-WAY DEDICATED TO THE CITY OF MOSES LAKE ON THE PLAT

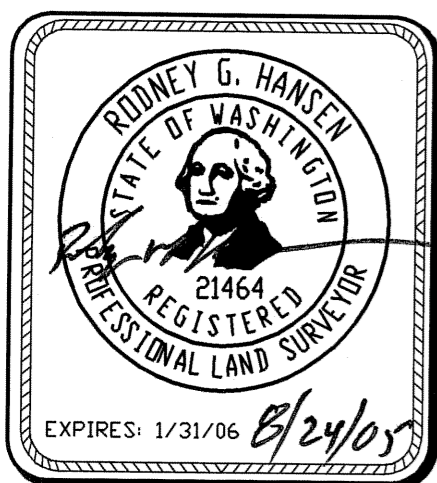
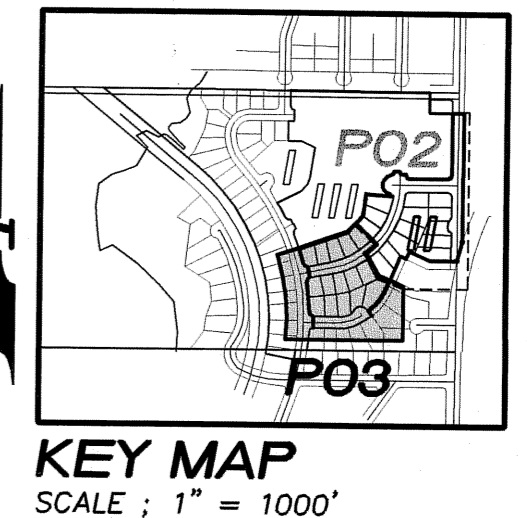
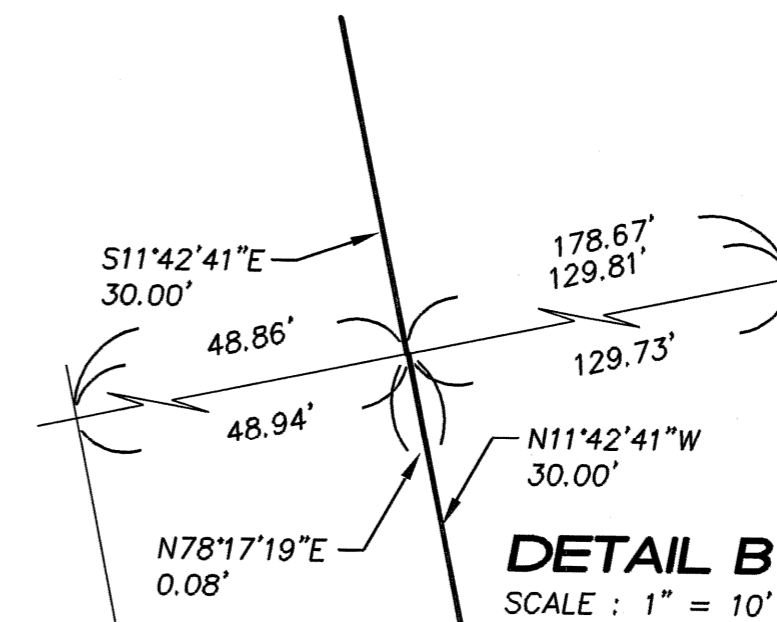

**Pacific Engineering Design, LLC**  
Civil Engineering and Planning Consultants

4180 LIND AVENUE S.W.  
RENTON, WA 98055  
PHONE: (425) 251-8811  
FAX: (425) 251-8880  
WEB SITE: PACENG.COM

## POWER POINTE MAJOR PLAT II

CITY OF MOSES LAKE, WA

FOR:  
SMART HOMES  
107 WASHINGTON  
ALGONA, WA 98001  
PHONE: (253) 833-7755, FAX: (253) 876-0530  
E-MAIL: SMARTHOMES108@COMCAST.NET

### PRELIMINARY PLAT POWER POINTE HORIZONTAL CONTROL PLAN

PROJECT NO.: 05065

DRAWN BY: JGC

ISSUE DATE: 08-24-05

SHEET REV.:

05065HC03-PHASE-II-P03.DWG

# P03