

A PORTION OF SEC 27, TWP 19 N., RGE 28 E., W.M. GRANT COUNTY, WASHINGTON

NOTE

- ① ROAD RIGHT-OF-WAY DEDICATED TO THE CITY OF MOSES LAKE ON THE PLAT

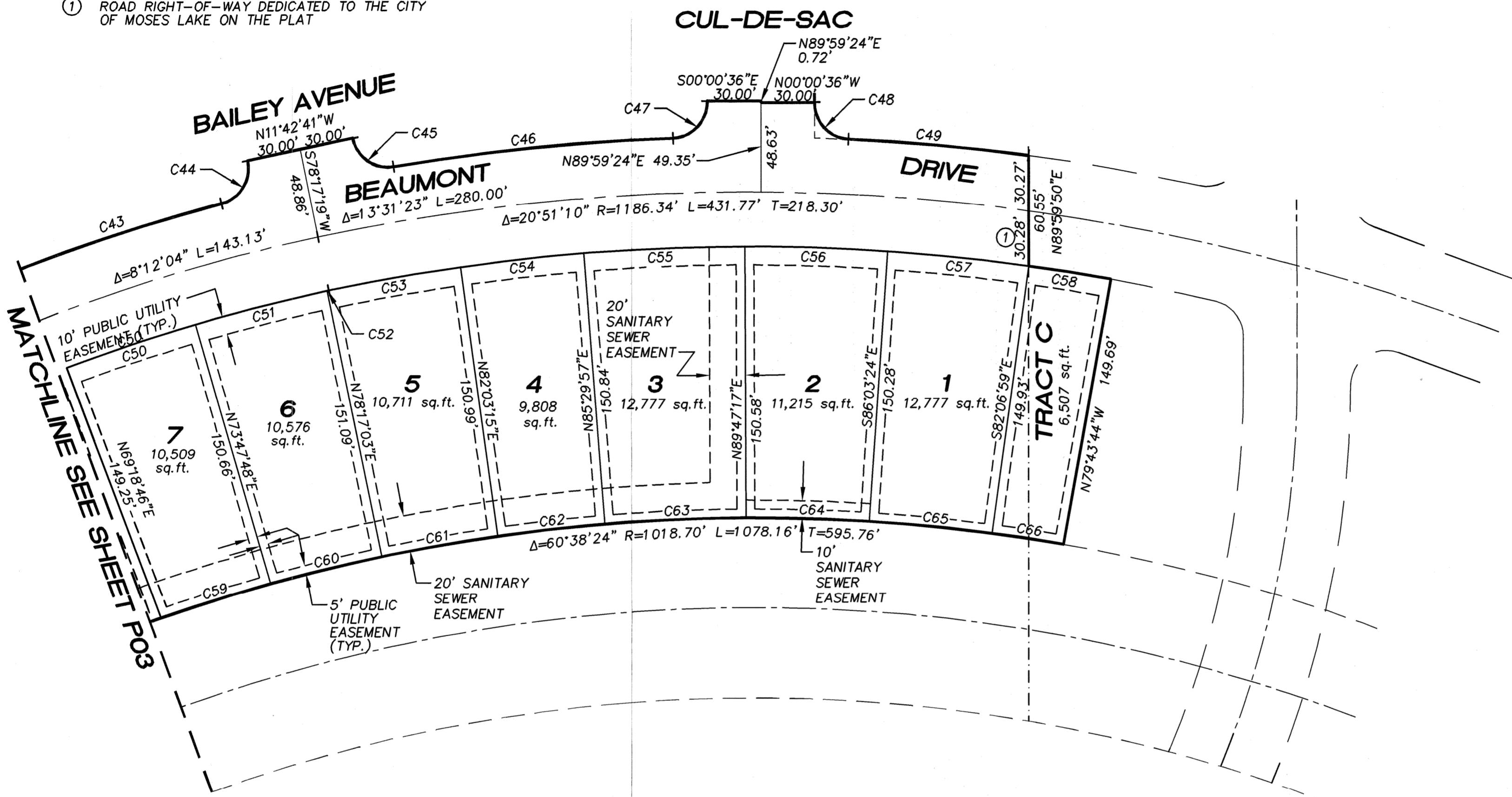
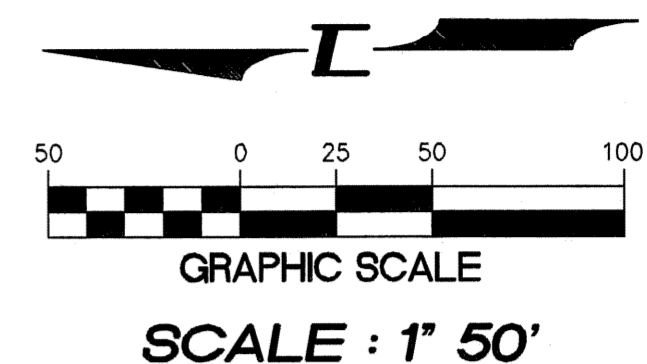

CURVE	DELTA	RADIUS	LENGTH	TANGENT	CURVE	DELTA	RADIUS	LENGTH	TANGENT
C43	8°51'05"	1030.00'	159.12'	79.72'	C55	4°28'48"	1156.34'	90.41'	45.23'
C44	87°19'33"	20.00'	30.48'	19.09'	C56	3°57'51"	1156.34'	80.00'	40.02'
C45	87°37'36"	20.00'	30.59'	19.19'	C57	3°56'25"	1156.34'	79.52'	39.78'
C46	7°25'25"	1216.34'	157.60'	78.91'	C58	2°18'25"	1156.34'	46.56'	23.28'
C47	88°05'44"	20.00'	30.75'	19.35'	C59	3°36'36"	1018.70'	64.19'	32.10'
C48	87°16'07"	20.00'	30.46'	19.07'	C60	3°36'29"	1018.70'	64.15'	32.09'
C49	4°46'15"	1216.34'	101.28'	50.67'	C61	3°42'32"	1018.70'	65.94'	32.98'
C50	4°29'02"	970.00'	75.91'	37.98'	C62	3°24'01"	1018.70'	60.46'	30.24'
C51	4°29'15"	970.00'	75.97'	38.01'	C63	4°27'03"	1018.70'	79.13'	39.59'
C52	0°03'45"	970.00'	1.06'	0.53'	C64	3°53'10"	1018.70'	69.09'	34.56'
C53	3°42'27"	1156.34'	74.82'	37.43'	C65	3°53'32"	1018.70'	69.20'	34.61'
C54	3°26'42"	1156.34'	69.53'	34.78'	C66	2°16'03"	1018.70'	40.32'	20.16'

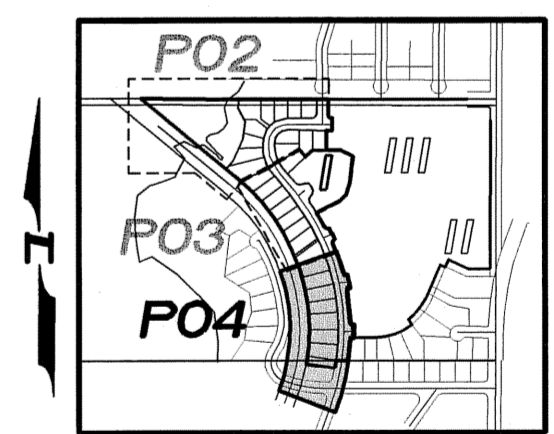

KEY MAP
SCALE: 1" = 1000'

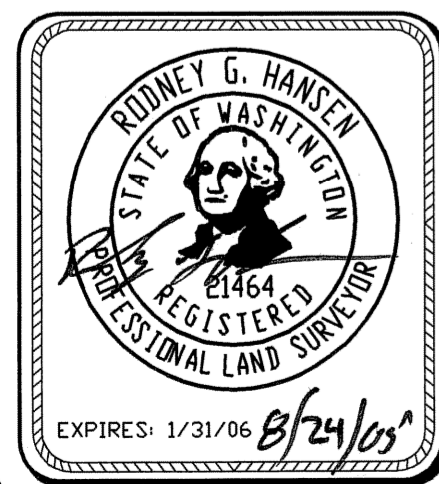

Pacific Engineering Design, LLC
Civil Engineering and Planning Consultants

4180 LIND AVENUE S.W.
RENTON, WA 98055
PHONE: (425) 251-8811
FAX: (425) 251-8880
WEB SITE: PACENG.COM

POWER POINTE MAJOR PLAT I

CITY OF MOSES LAKE, WA

FOR:
SMART HOMES
107 WASHINGTON
ALGONA, WA 98001
PHONE: (253) 833-7755, FAX: (253) 876-0530
E-MAIL: SMARTHOMES108@COMCAST.NET

PRELIMINARY PLAT POWER POINTE HORIZONTAL CONTROL PLAN

PROJECT NO.: **05065**
DRAWN BY: **JGC**
ISSUE DATE: **08-24-05**
SHEET REV.:

05065HC04-PHASE-I-P04.DWG
P04