

REVISIONS:

PORTION OF N.E. 1/4 S.W. 1/4 SEC. 34, T. 24N., R. 5 E., W.M.

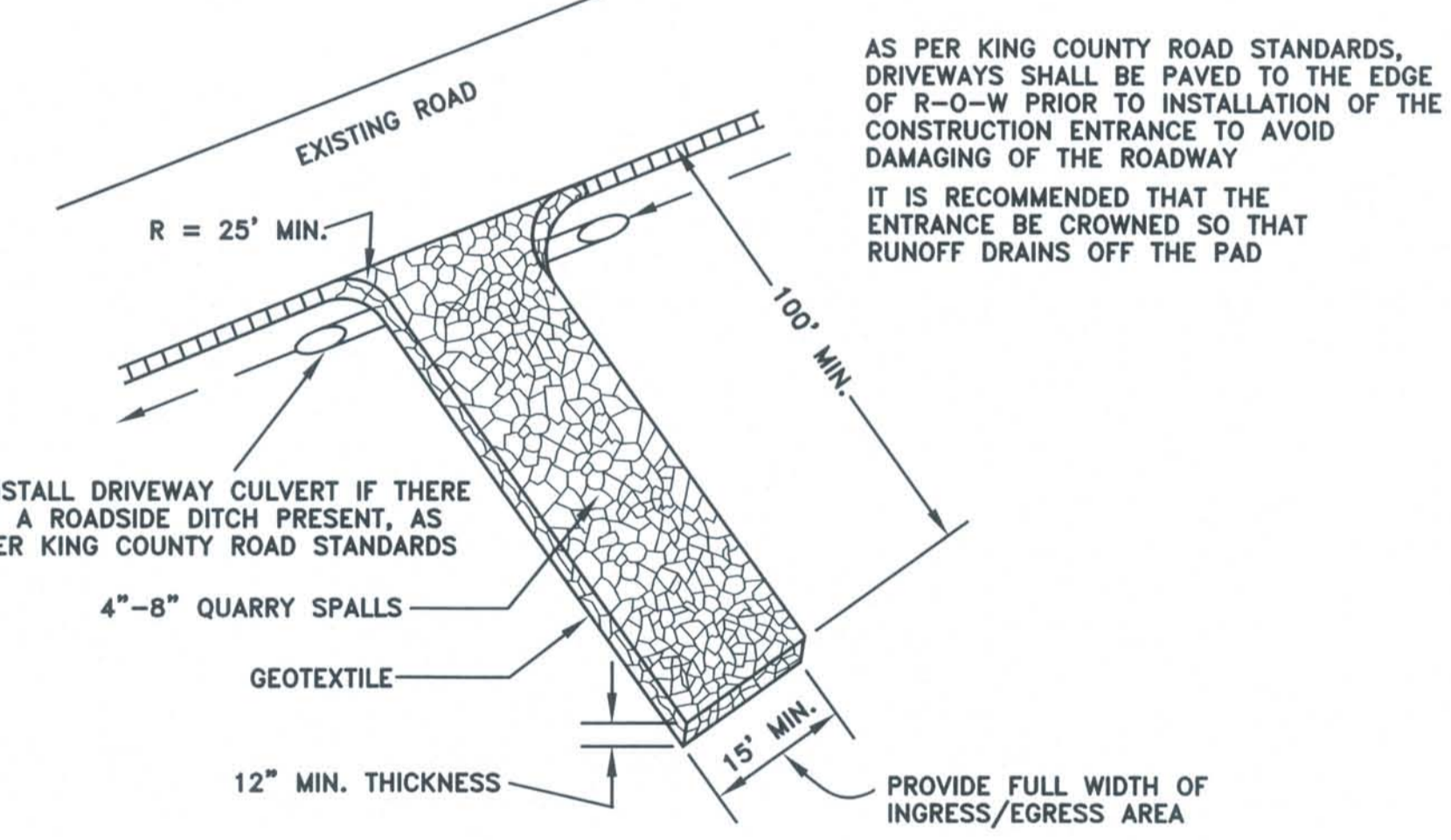

CONSTRUCTION ENTRANCE DETAIL

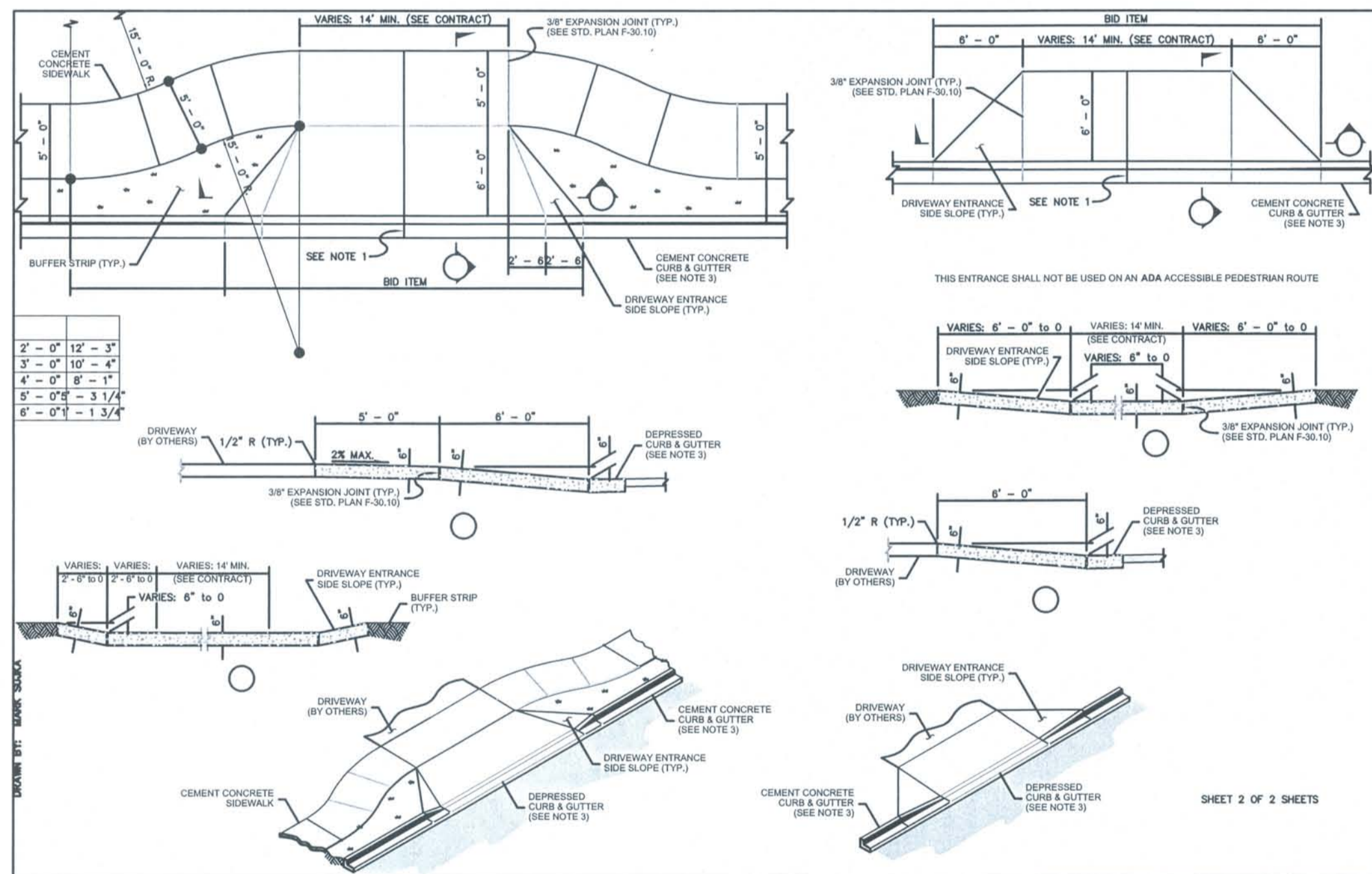
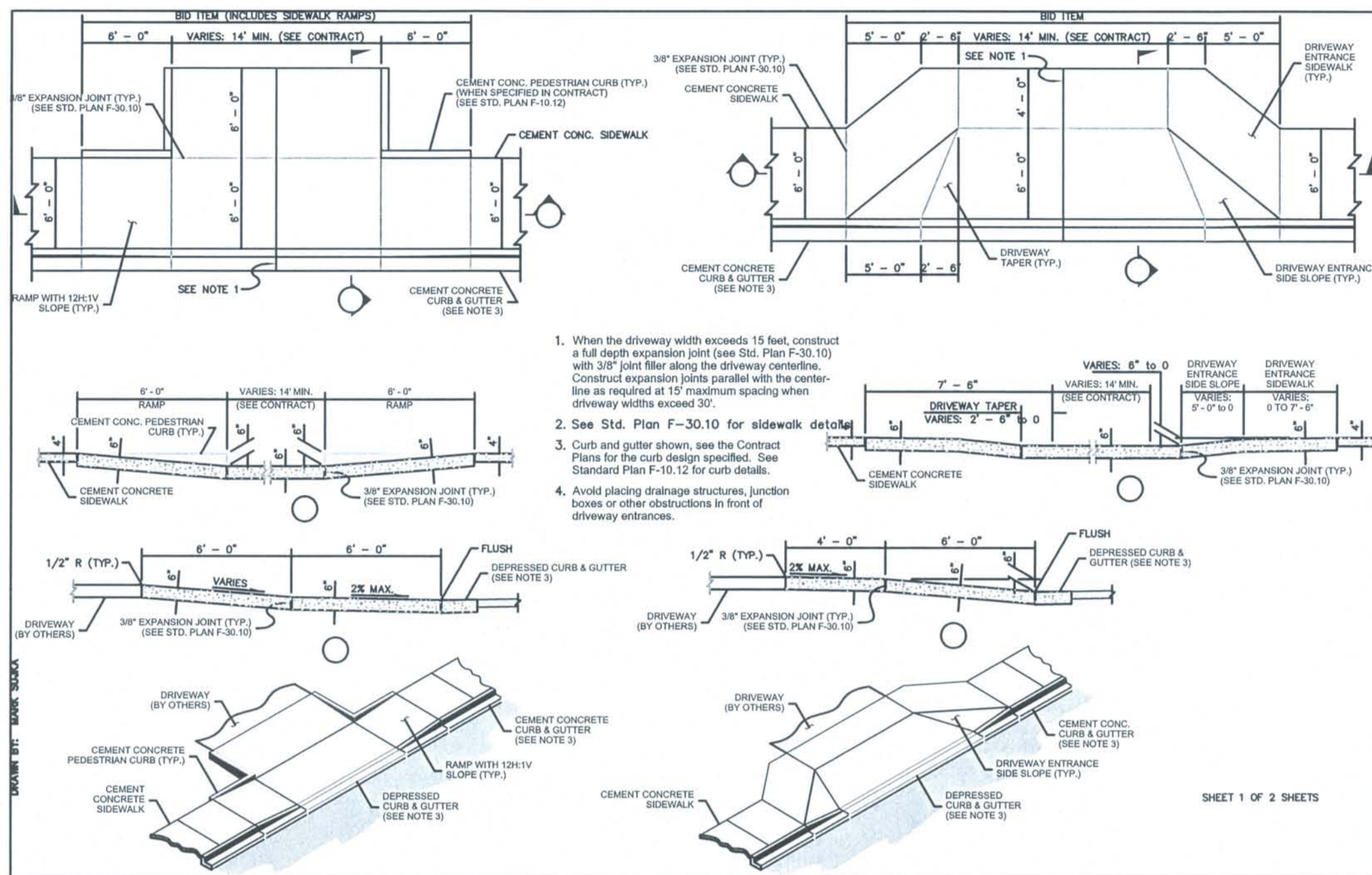
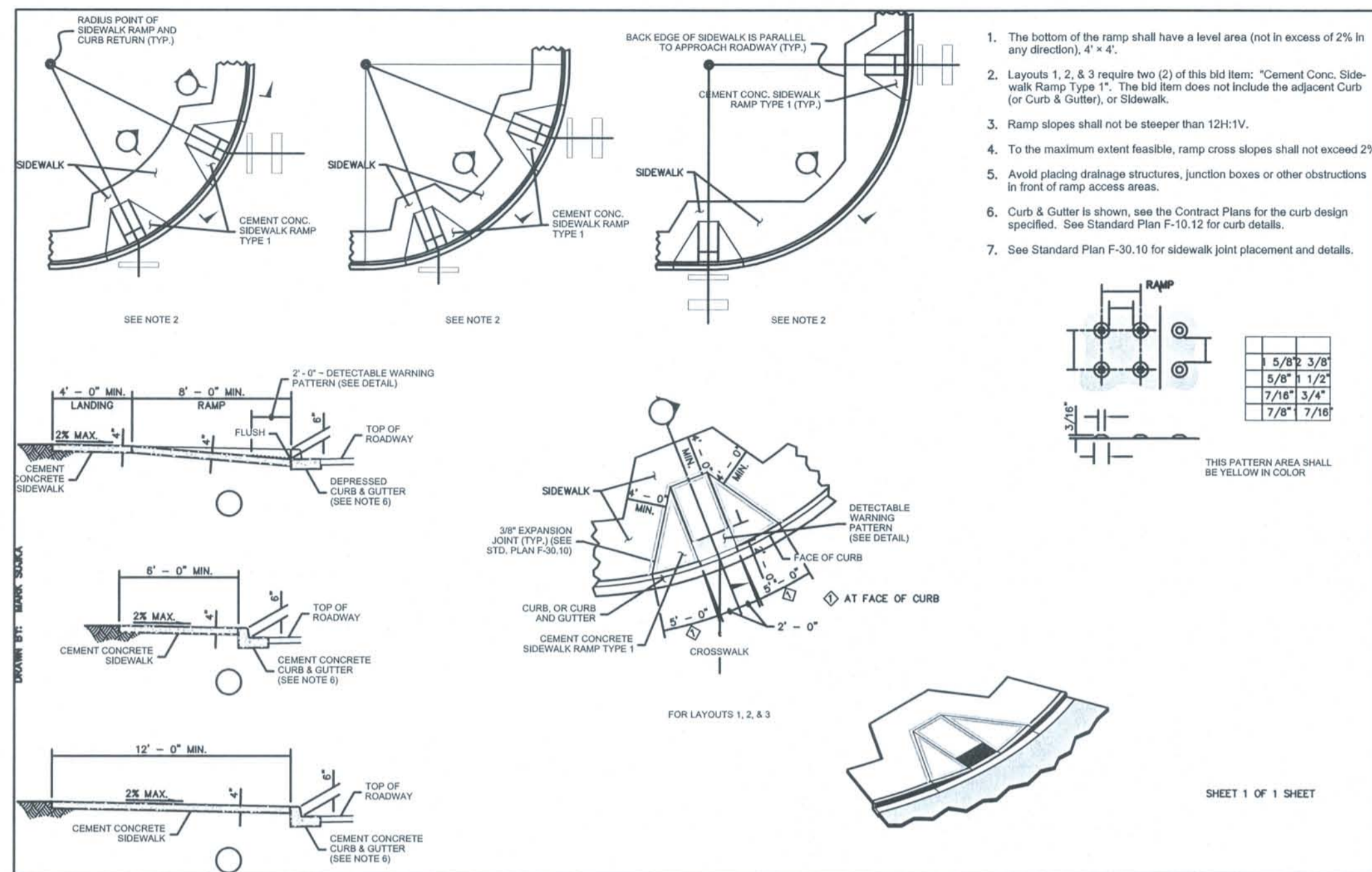
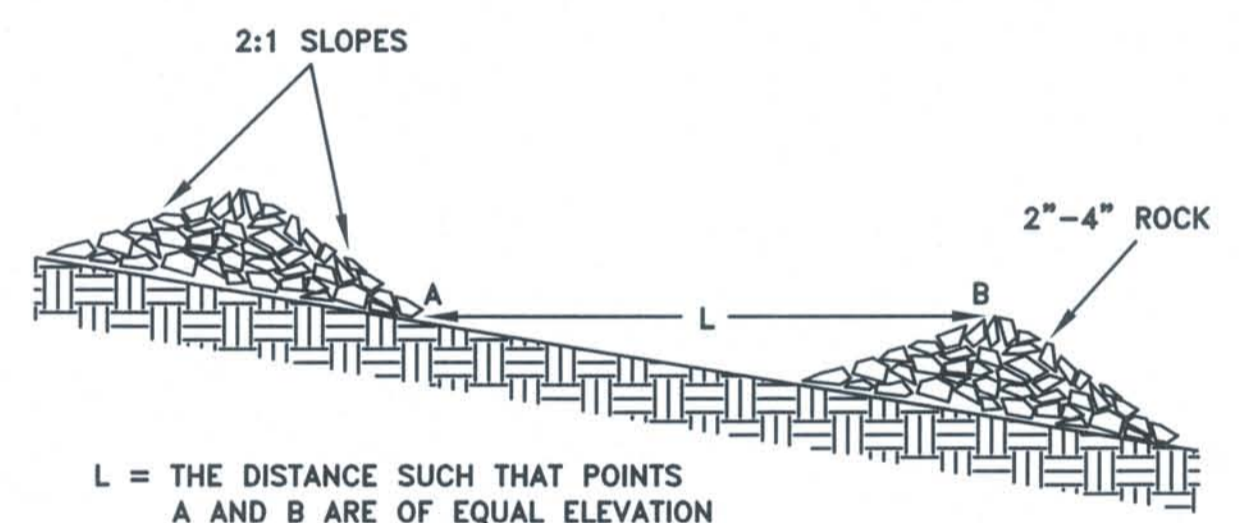

ROCK CHECK DAM DETAIL

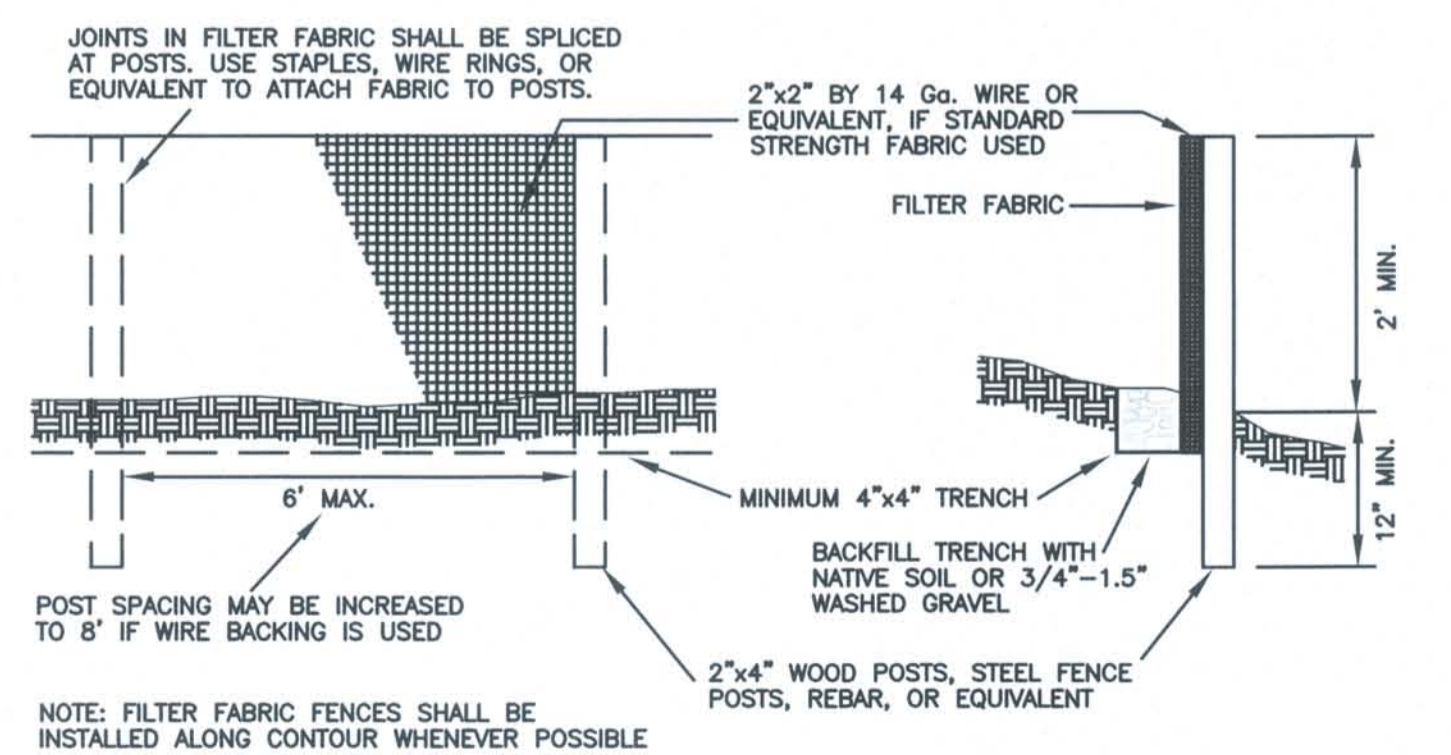

SILT FENCE DETAIL

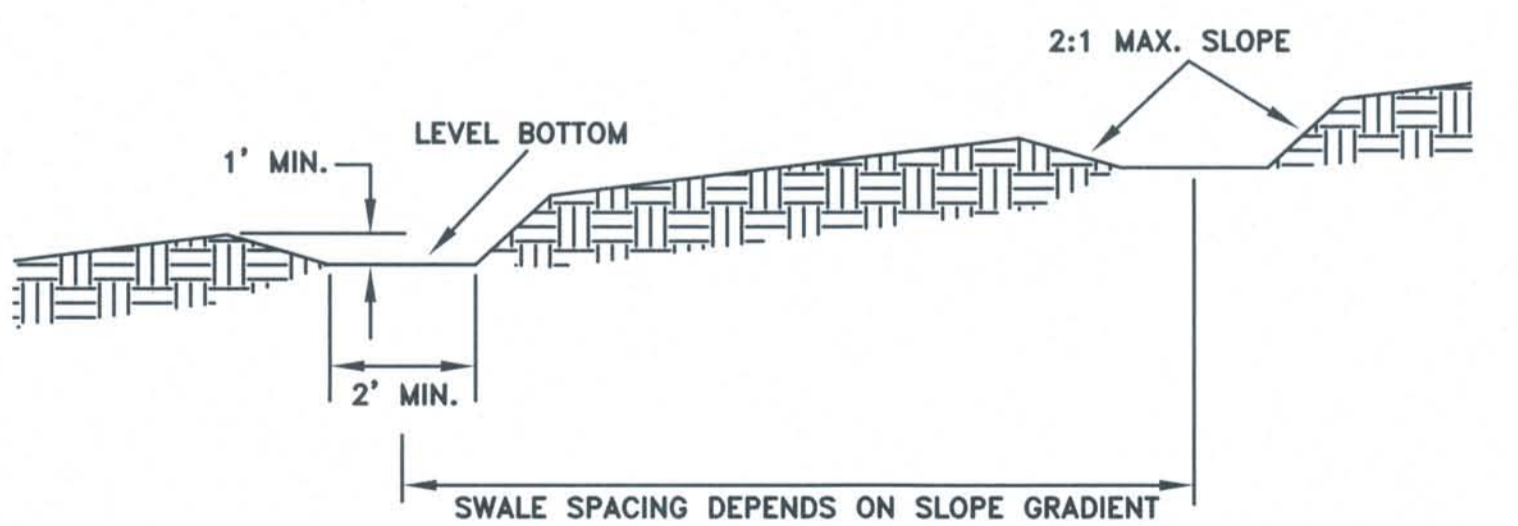

INTERCEPTOR DITCH DETAIL

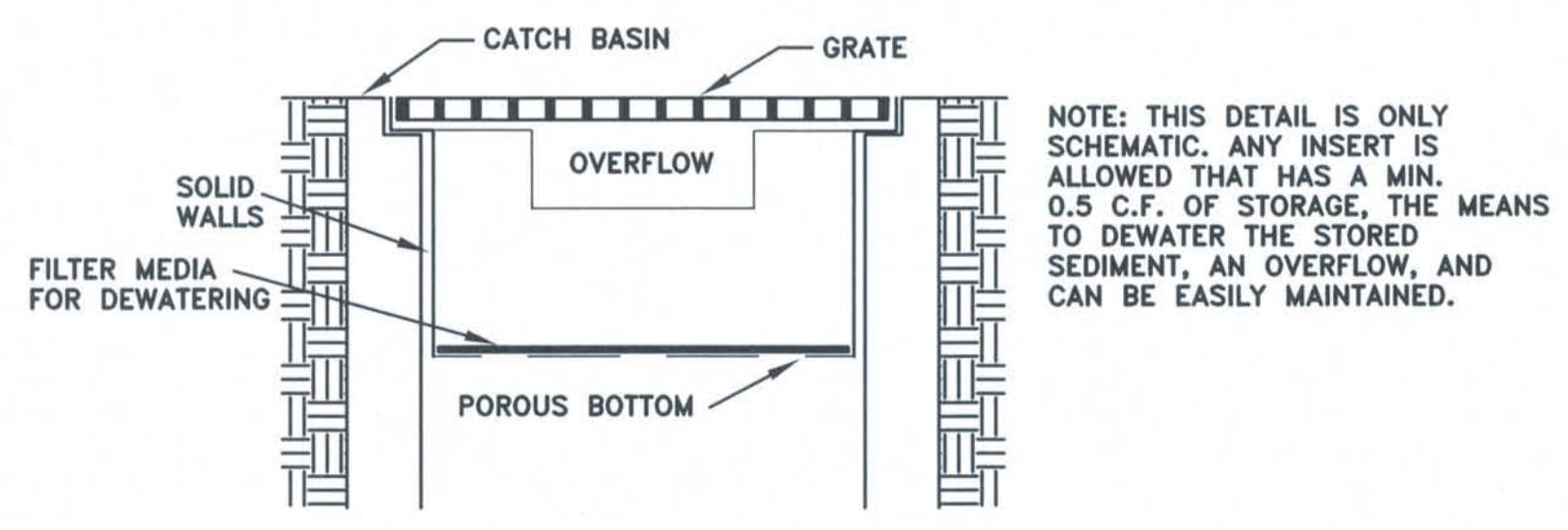

CB PROTECTION DETAIL



15445 53RD AVE S
SEATTLE, WA 98188
PHONE: (206) 431-7970
FAX: (206) 388-1648
WEB SITE: PACENG.COM

Pacific Engineering Design, LLC
Civil Engineering and Planning Consultants

TRACT 'J' SUBDIVISION
CITY OF NEWCASTLE

FOR THE HIGHLANDS AT NEWCASTLE, LLC
1000 1ST AVE S STE 100
SEATTLE, WA 98108
PHONE: (425) 739-3890
FAX: (425) 827-0462

PROJECT NO.: 07052
DRAWN BY: ENM
ISSUE DATE: 07-02-08
SHEET REV.: 01-06-09

NOTES AND DETAILS

07052NT01-P07-P08.DWG
P07