

Table 1

WATER MAIN STANDARD PIPE MATERIAL

TYPE OF PIPE	AWWA (ASTM) STANDARD		
	PIPE	JOINT	FITTINGS
Ductile Iron	C 151 & C104	C 111	C 153

NOTE:

For perpendicular construction, maintain 18" separation or construct waterline passing over sewer line and use water main standards setforth above for the sewer with minimum 18 feet length centered over crossing.

DETAIL NO. 1
PARALLEL CONSTRUCTION

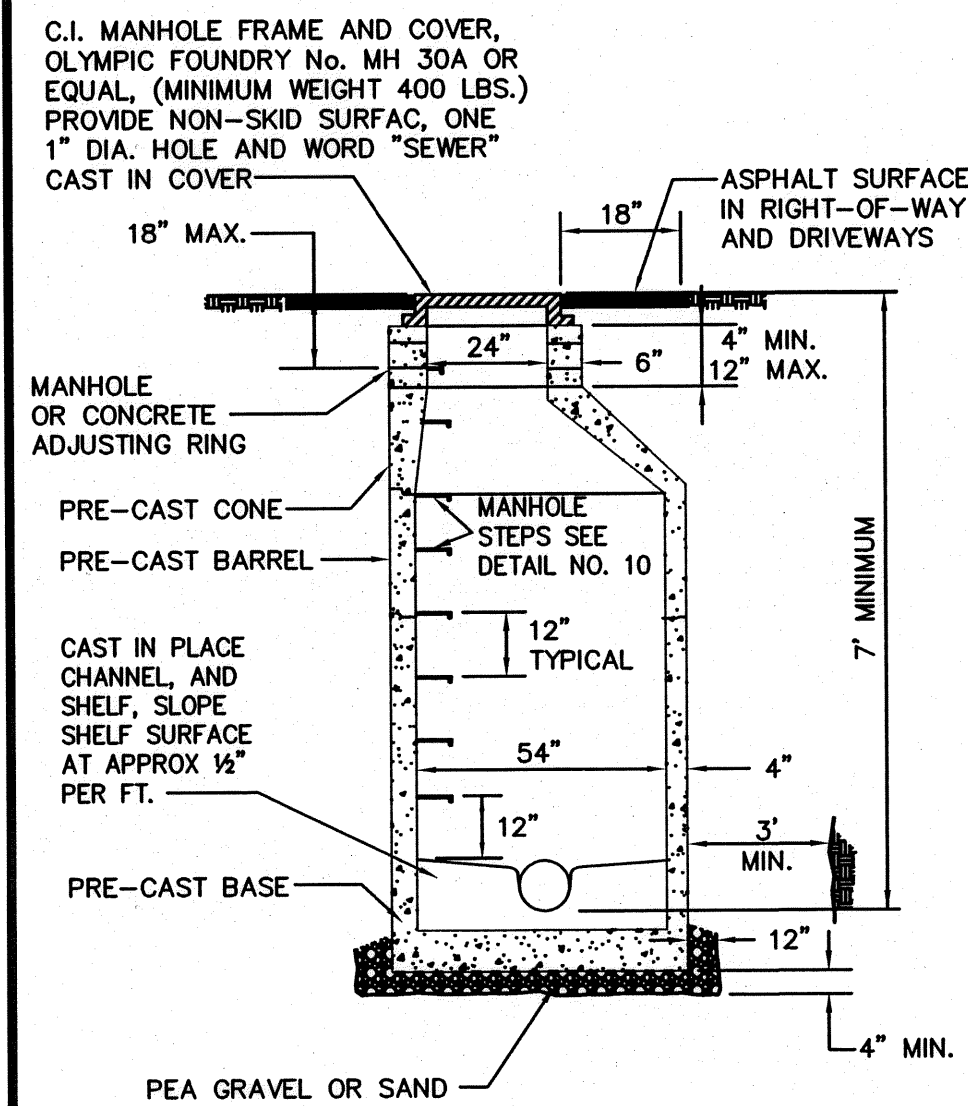

TYPICAL FOR 54" MANHOLE

NOTES:

- Details shown are typical for all manholes unless otherwise noted.
- A 2 inch thick, 6 foot diameter asphalt pad is to be placed around the rim of manholes in unpaved areas.
- Manholes with depths of 20 feet and greater need to be 72" diameter with a safety platform. Ask for detail.
- Provide a minimum three foot clearance from outside face of manhole to excavation in order to use a hoepac during compaction.
- All Manholes shall have all interior surfaces, including channelling, coated (sealed) with a high solids urethane coating, Wasser MC-AROSHIELD or approved equal. Color of coating shall be white.

DETAIL NO. 2
STANDARD MANHOLE

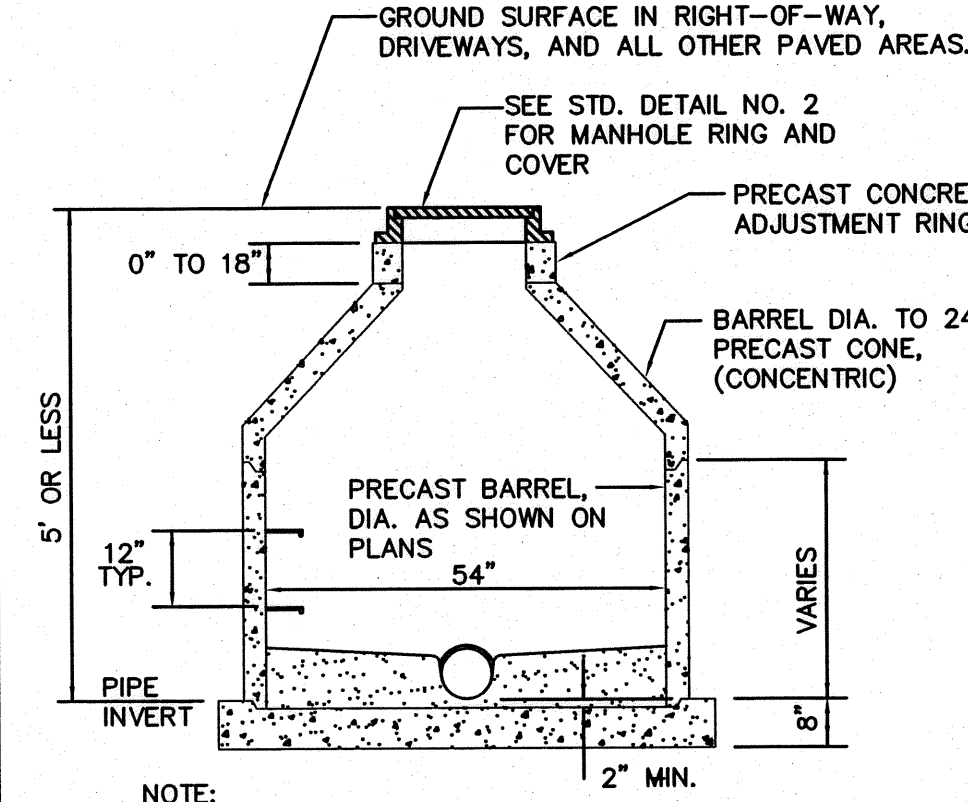

TYPICAL FOR 54" MANHOLE
DETAIL NO. 3
SHALLOW MANHOLE

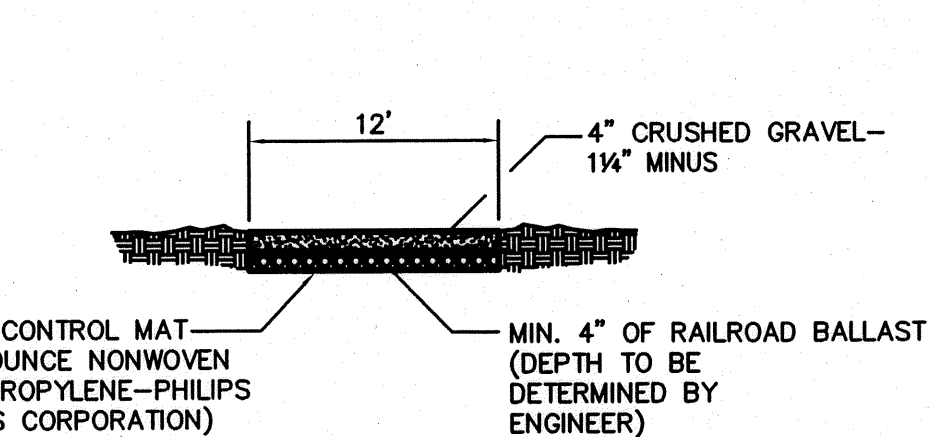

DETAIL NO. 15
ACCESS ROAD

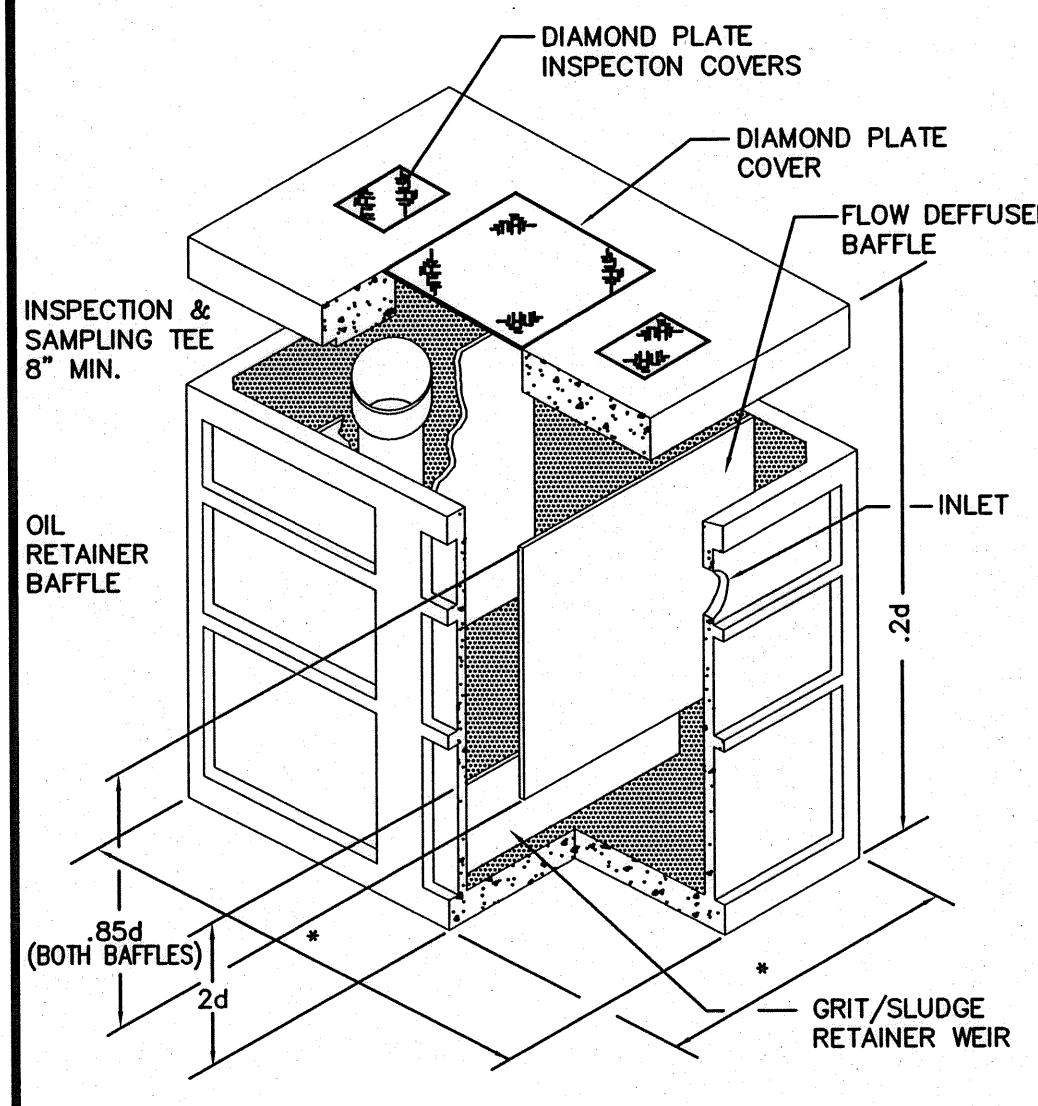

NOTE:
* OIL SEPARATOR TO BE SIZED TO HAVE A RETENTION TIME OF 45 MINUTES OR TO HAVE A MIN. OF 600 GALLONS OF TREATMENT CAPACITY.

DETAIL NO. 4
TYPICAL OIL SEPARATOR (600 gal. min.)

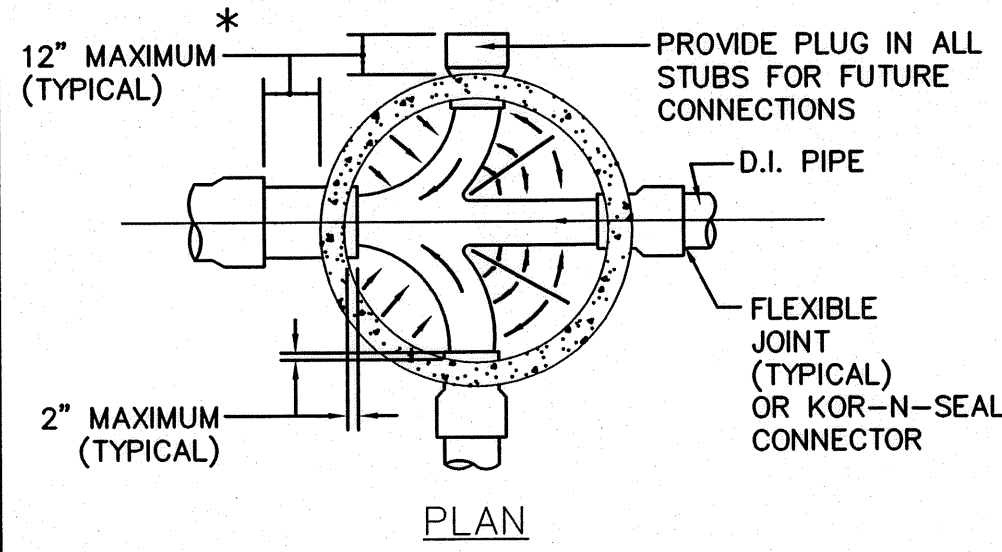

DETAIL NO. 5
MANHOLE BASE - BRANCHING SEWERS

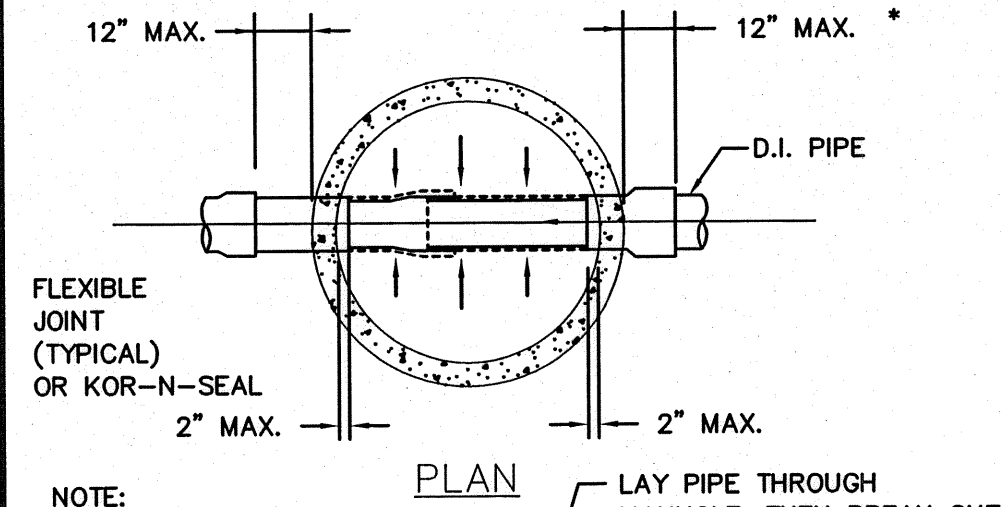

DETAIL NO. 6
MANHOLE BASE
STRAIGHT THROUGH FLOW

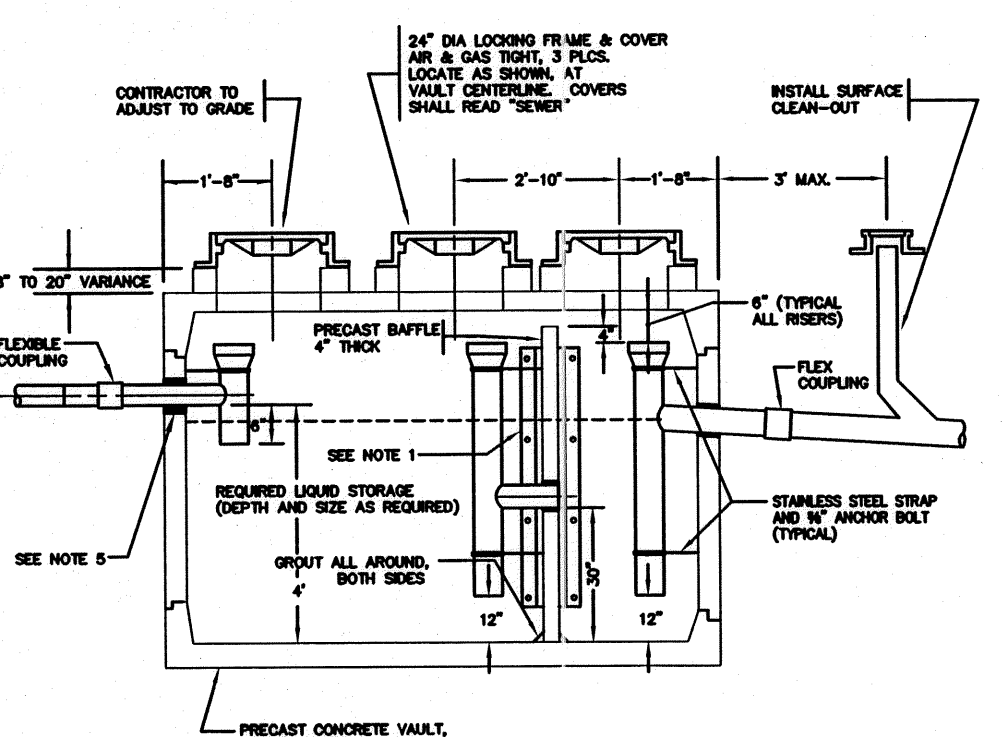

- NOTES:
- IF VAULT IS NOT SLOTTED TO ACCEPT PRECAST CONC. BAFFLE SHALL BE HELD IN PLACE BY (2) 3" x 3" x 1/2" ANGLE (4FT. LONG) ATTACHED TO VAULT WALL WITH (4 EA.) 1" BOLTS AND NUTS (WITH WASHERS) SPACED 14" O.C. ANGLE AND FASTENERS SHALL BE STAINLESS STEEL, OR GALVANIZED AND ASPHALT COATED.
 - PRECAST VAULT AND BAFFLE SHALL HAVE KNOCKOUTS AT ALL PIPE OPENINGS. IF KNOCKOUTS ARE NOT PRESENT THEN PIPE OPENINGS SHALL BE CORE-DRILLED. PIPE OPENINGS SHALL BE 2" LARGER THAN PIPE DIAMETER.
 - POSITION RISERS BELOW ACCESS OPENINGS TO ALLOW CLEAR ACCESS TO RISER AND VAULT CHAMBER.
 - LOCATE INTERCEPTOR WITHIN 20' OF DRIVE FOR ACCESS BY MAINT. VEHICLE.
 - CONNECTIONS TO CONCRETE WALLS WITH P.V.C. PIPE REQUIRE KOR-N-SEAL CONNECTOR OR A.C. x P.V.C. BRANT ADAPTER. SEAL ALL PIPE CONNECTIONS WITH NONSHRINK GROUT.
 - LINE-SIZED P.V.C. PIPE SHALL BE USED THROUGHOUT.
 - GRAY-WATER ONLY. BLACK-WATER SHALL BE CARRIED BY SEPERATE SIDE SEWER.
 - CLEAN-OUT REQUIRED 3' MAX. DOWNSTREAM OR INTERCEPTOR.
 - FILL WITH CLEAN WATER PRIOR TO START UP OF SYSTEM.
 - SIZE WILL BE PER UNIFORM PLUMBING CODE APPENDIX H. (750 GAL. MIN.)

DETAIL NO. 7
TYPICAL VEGETABLE-ANIMAL
FAT & GREASE INTERCEPTOR

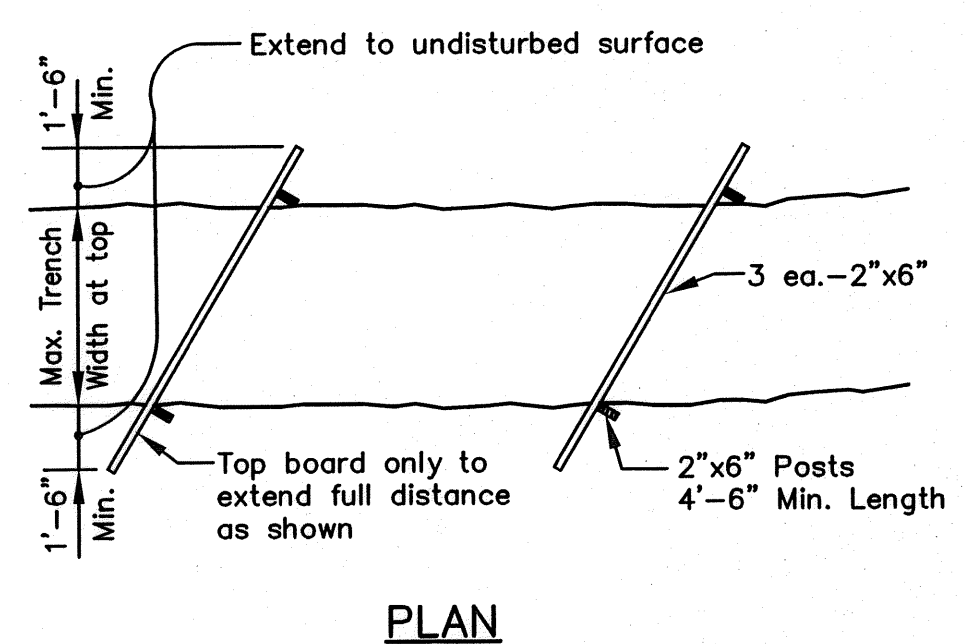
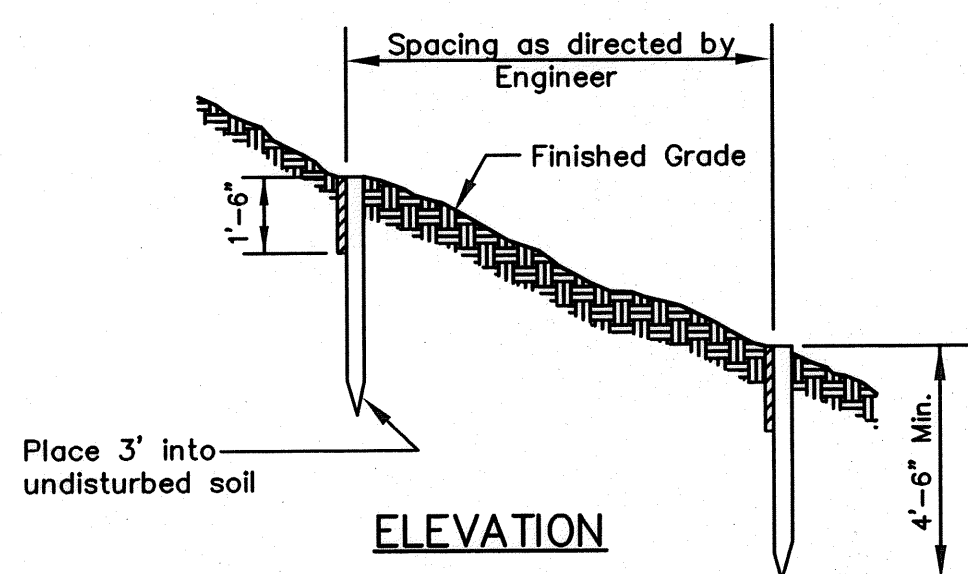

- Notes:
- Timber baffles to be installed where directed by the Engineer or District Inspector.
 - All backfill shall be seeded.

DETAIL NO. 9
HILL HOLDER

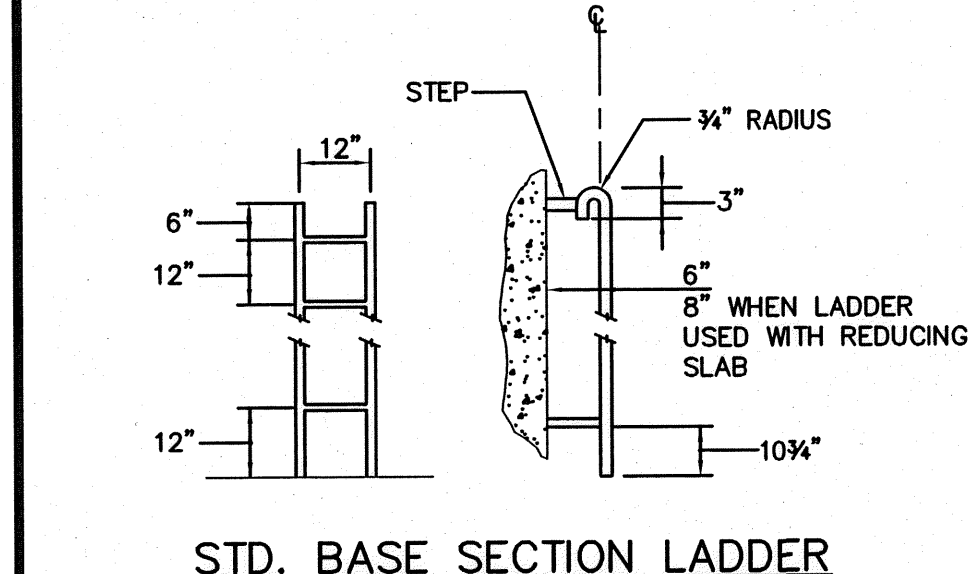

STD. BASE SECTION LADDER

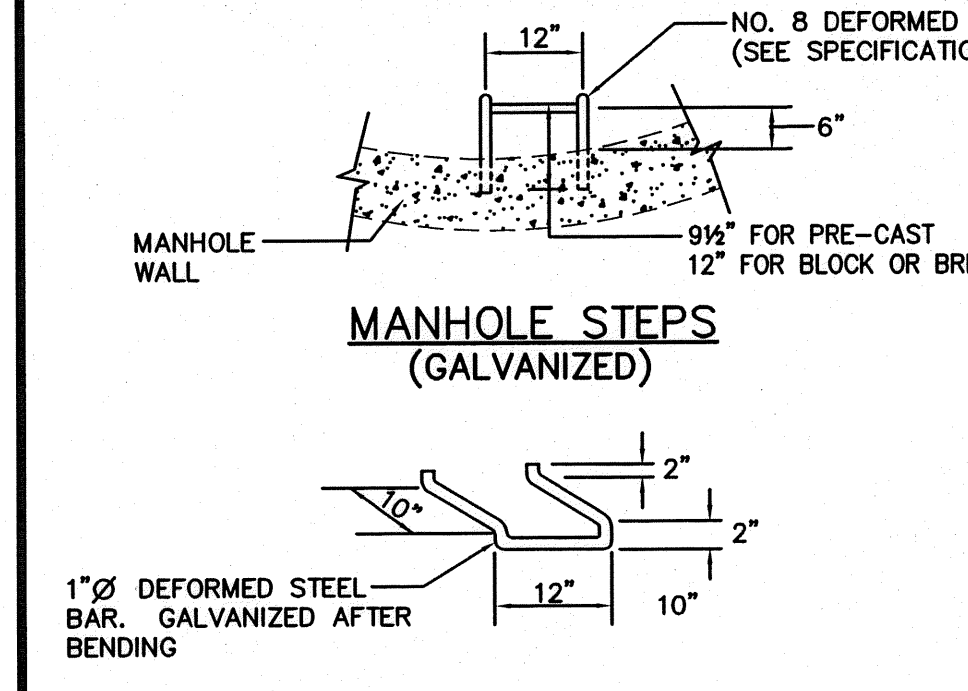

NOTE:
POLYPROPYLENE STEPS MAY BE SUBSTITUTED FOR GALVANIZED. POLYPROPYLENE MANHOLE STEPS SHALL BE LANE MODEL P-14938 OR APPROVED EQUAL.

DETAIL NO. 10
MANHOLE STEP DETAILS

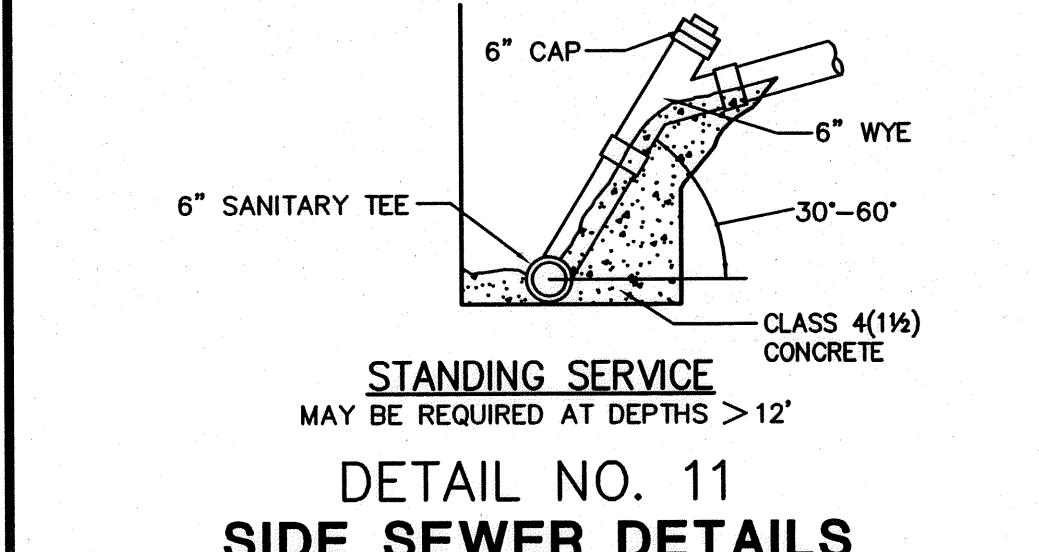
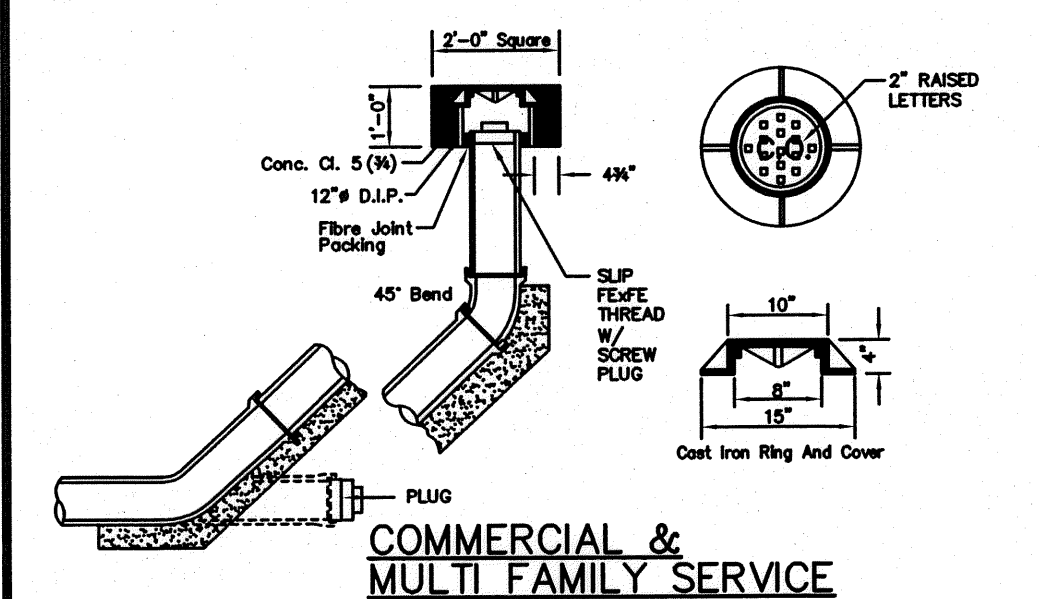
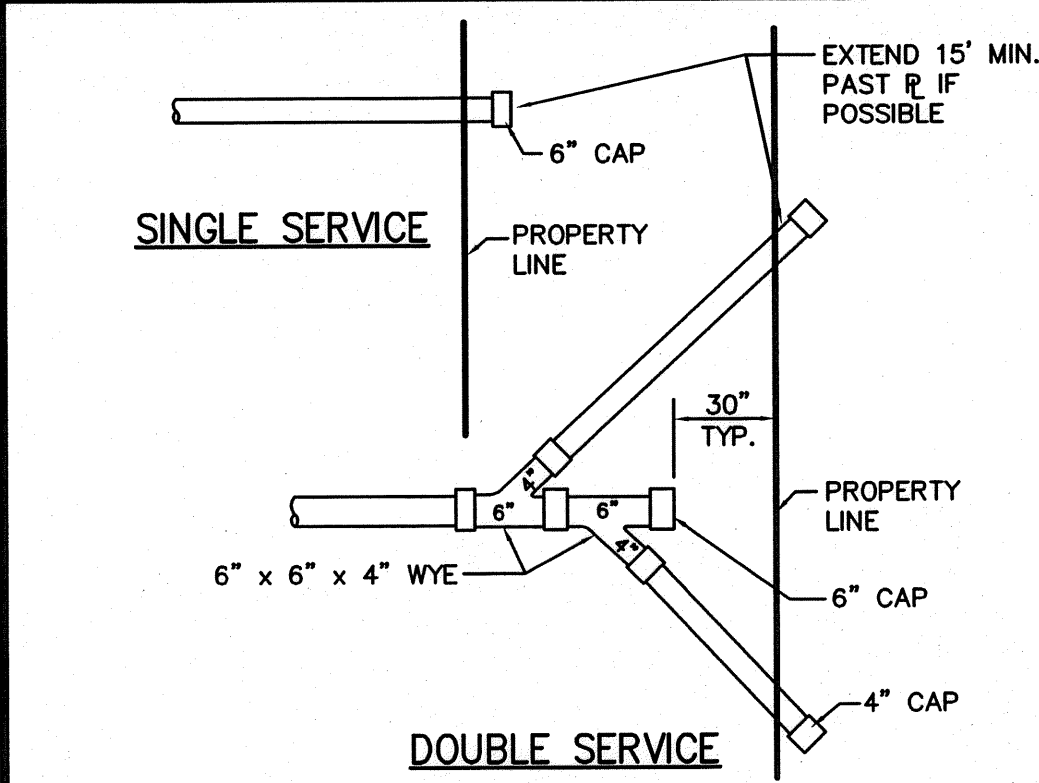

DETAIL NO. 11
SIDE SEWER DETAILS

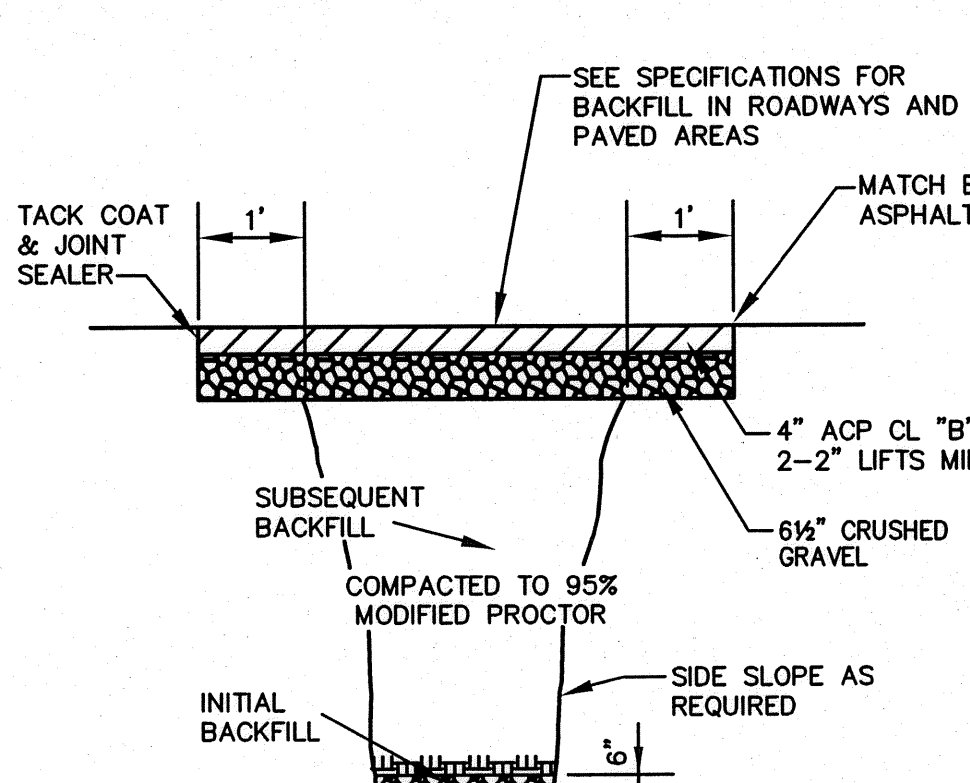

MIN. WIDTH: WHEN h IS LESS THAN 1', MIN. WIDTH = O.D. + 16".
WHEN h IS GREATER THAN 1', MIN. WIDTH = O.D. + 24".

DETAIL NO. 12
TRENCH CROSS SECTION FOR
P.V.C. OR D.I. PIPE

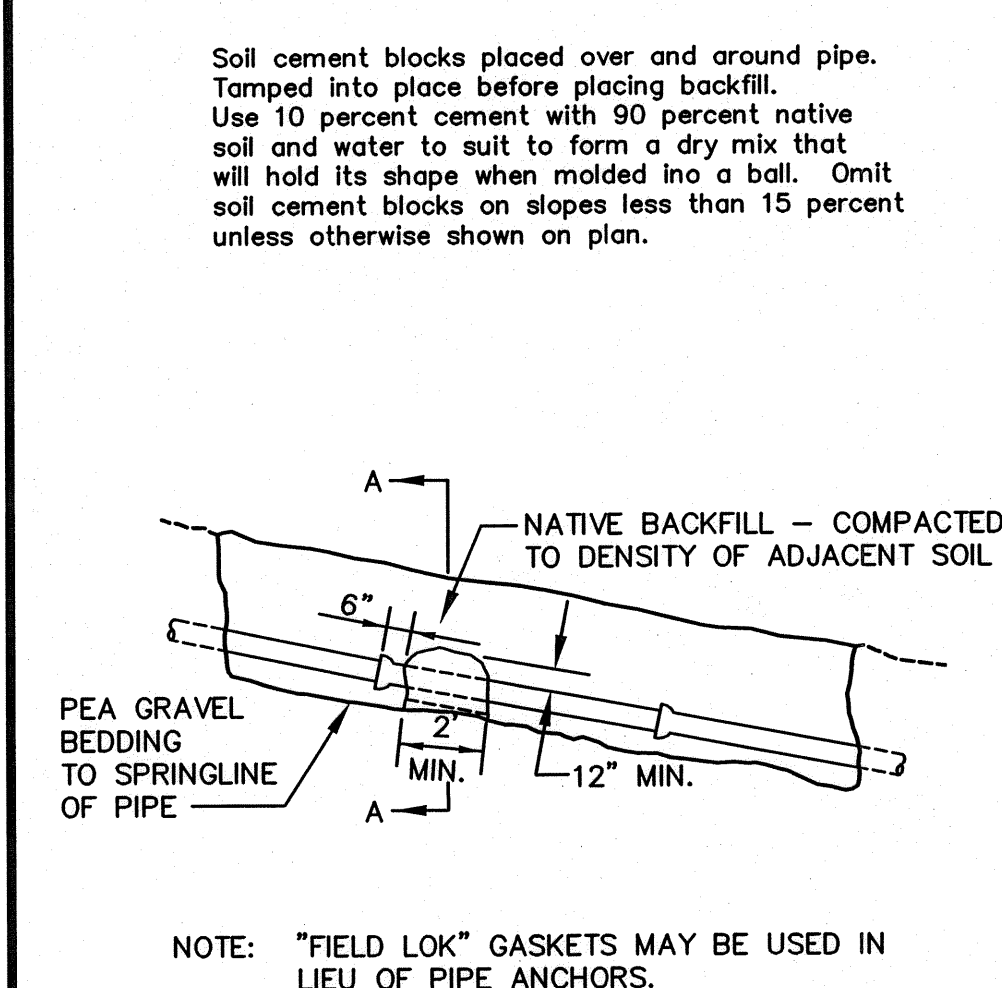
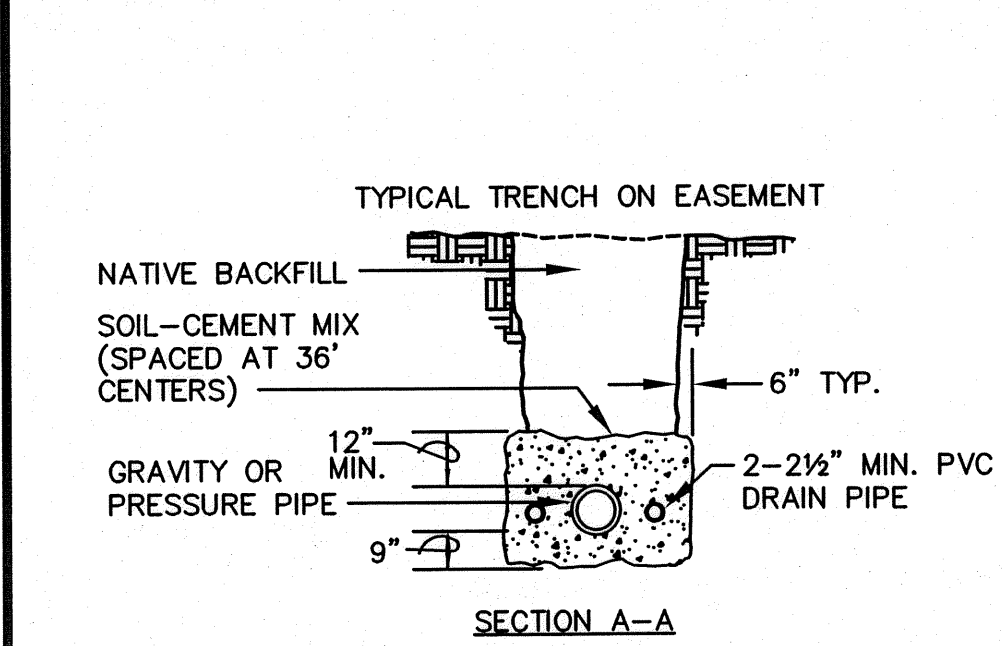

DETAIL NO. 13
PIPE ANCHOR

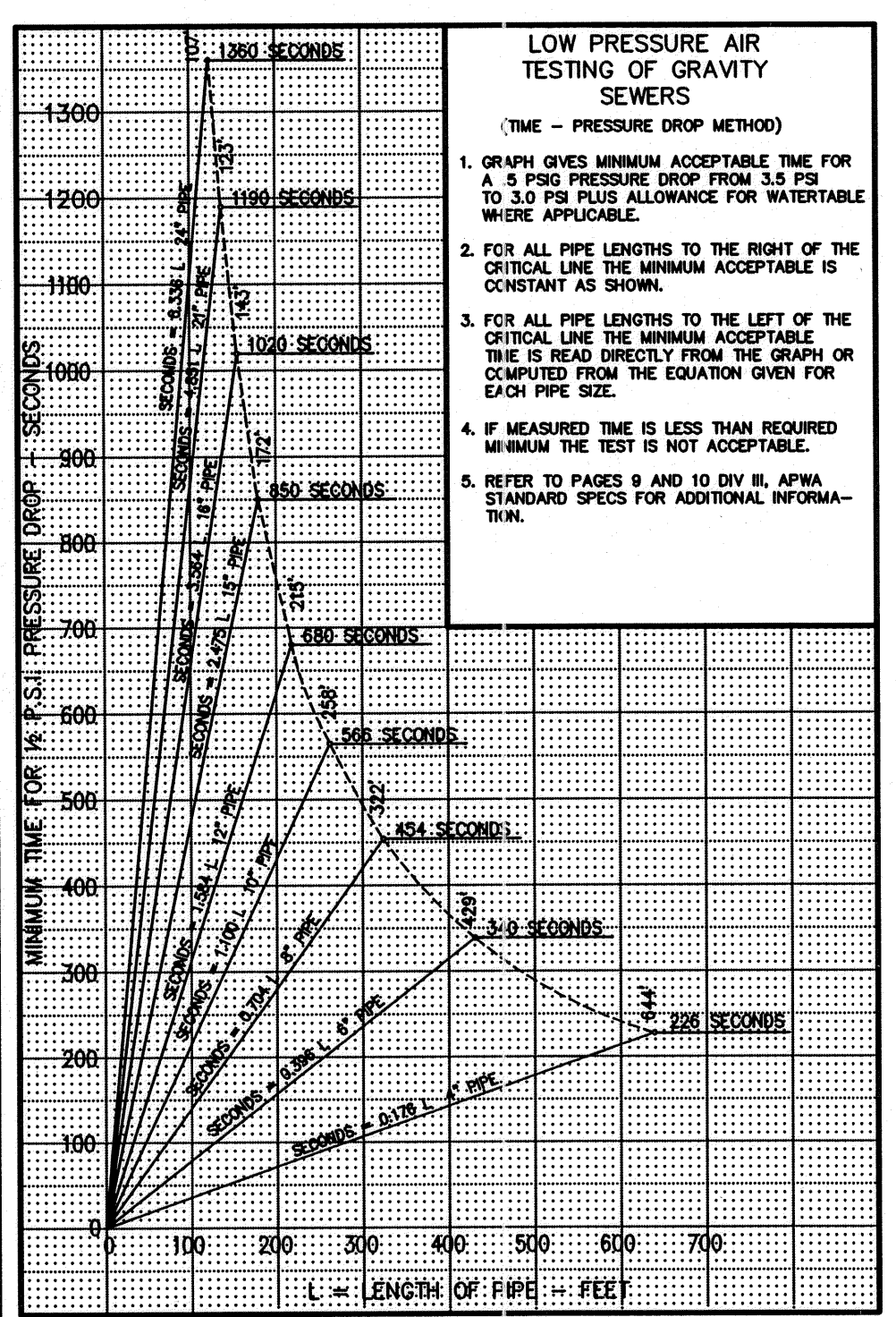

DETAIL NO. 14
LOW PRESSURE AIR TESTING OF
GRAVITY SEWERS

DESIGNED					
DRAWN	JRL				
CHECKED	DGS				
SYMBOL	SYMBOL	REVISION	DATE	BY	APP'D

Pacific Engineering Design, LLC
15445 53RD AVE. S. SEATTLE, WA 98188
PHONE: (206) 431-7970 FAX: (206) 388-1648 WEB SITE: PACENG.COM
Civil Engineering and Planning Consultants

COAL CREEK UTILITY DISTRICT
6801 132ND PLACE S.E.
NEWCASTLE, WASHINGTON 98059

REFERENCE INFORMATION	DATE
FIELD BOOK:	JULY 26, 2007
SURV. CPU FILE:	SCALE
DATUM: NGVD29	NOTED

VARNEY SUBDIVISION
STANDARD DETAILS

JOB NUMBER	07020.00
DWG NO	NOB01SSD-T-PS.DWG
SHEET	6 OF 7