

N.W. 1/4, SEC. 26, T. 21 N., R. 4 E., W.M.

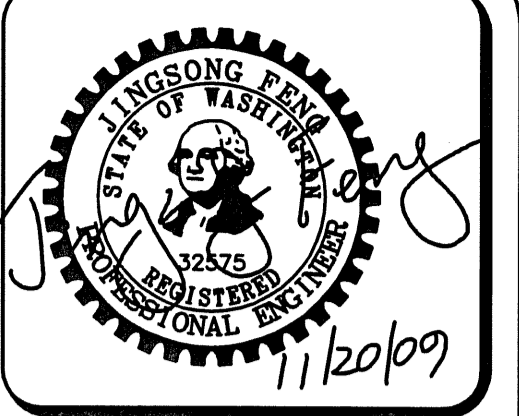

15445 53RD AVE. S.  
SEATTLE, WA 98188  
PHONE: (206) 431-7970  
FAX: (206) 388-1648  
WEB SITE: PACENG.COM

**Pacific Engineering Design, LLC**  
Civil Engineering and Planning Consultants

**PEPPER HILL ESTATES**  
KING COUNTY, WA.

FOR:  
PACIFIC HOUSING GROUP I, LLC  
1420 5TH AVE. SUITE 2200  
SEATTLE, WA 98101-1546  
PHONE: (206) 521-5979 FAX: (206) 224-2880

PROJECT NO.: **05052**  
DRAWN BY: **JGC/RRJ**  
ISSUE DATE: **06-22-07**  
SHEET REV.: **11-20-09**

**TYPICAL STREET SECTIONS**

05052D101-RW20.DWG  
**R20**

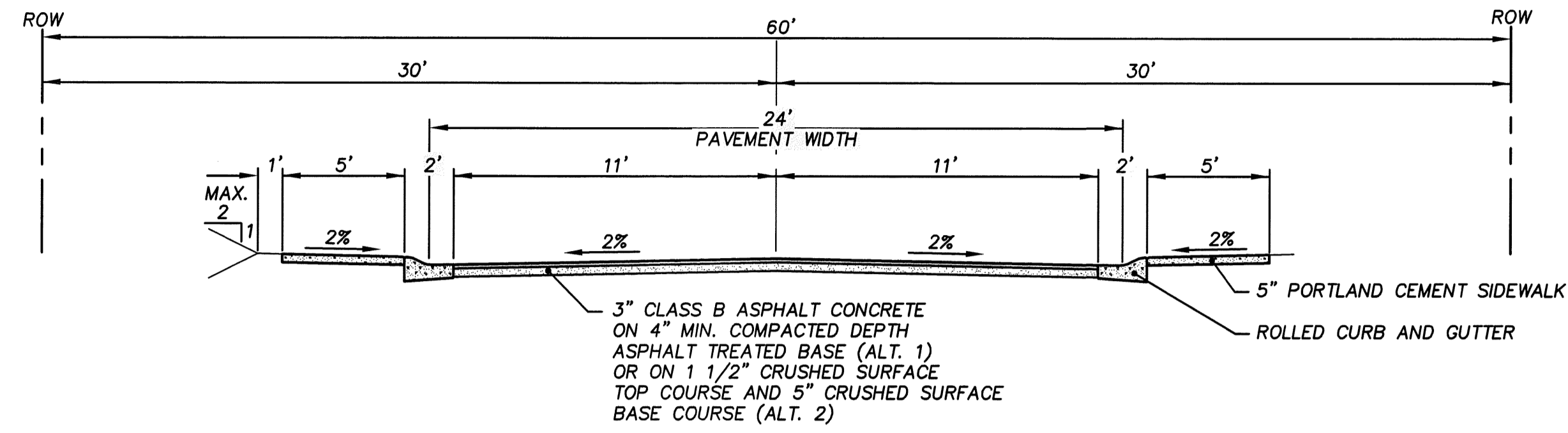

**SUBACCESS URBAN SECTION A-A**  
S 354TH ST  
57TH AVE S/S 356TH ST/56TH AVE S 18+13.02 TO 29+89.59

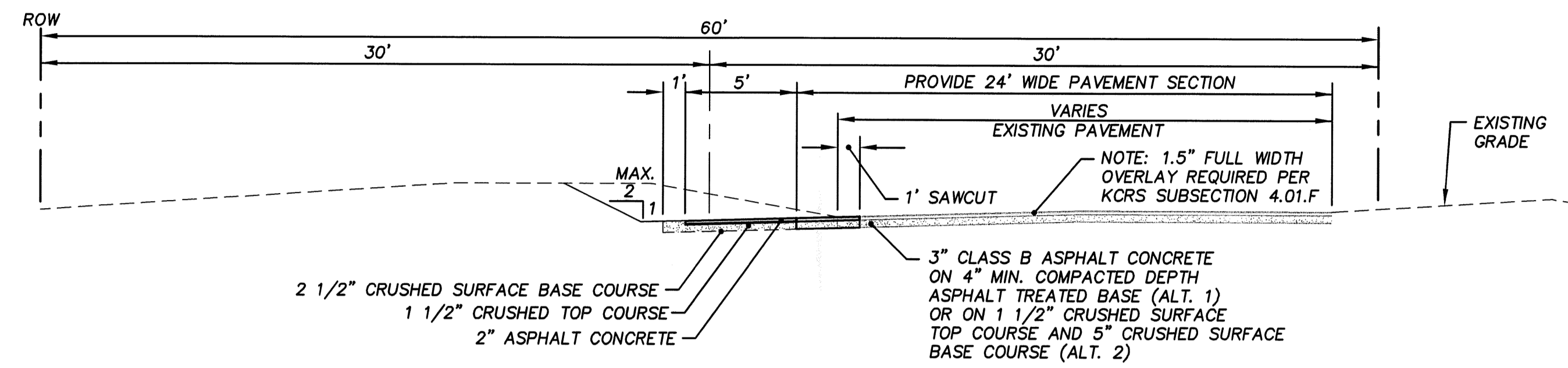

**NEIGHBORHOOD COLLECTOR URBAN - HALF STREET LEFT SECTION E-E**  
352ND ST S

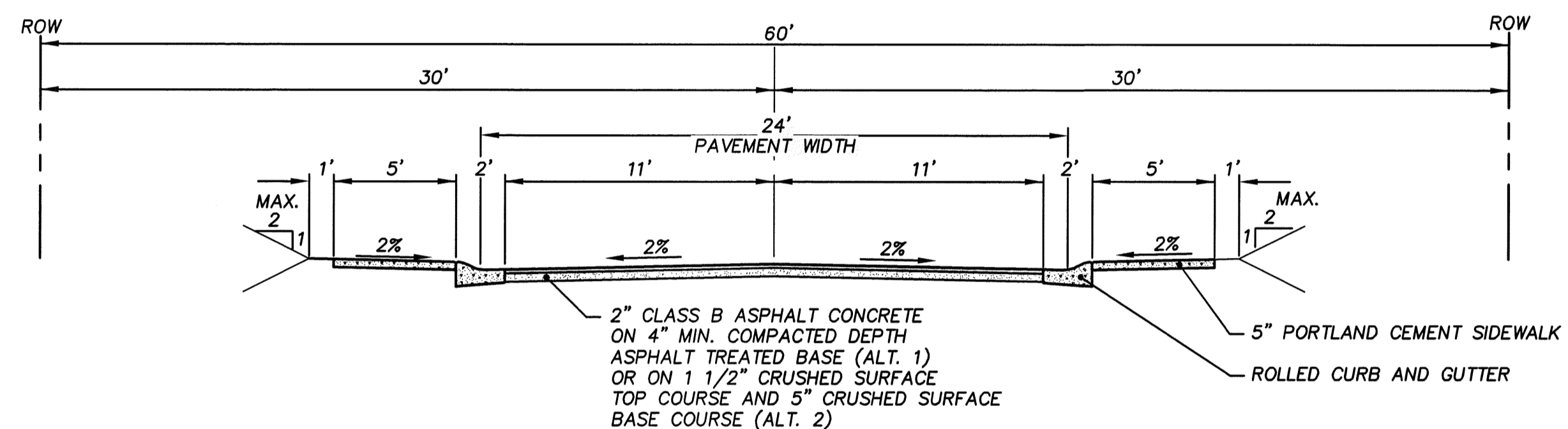

**SUBACCESS STREETS URBAN SECTION B-B**  
56TH AVE S

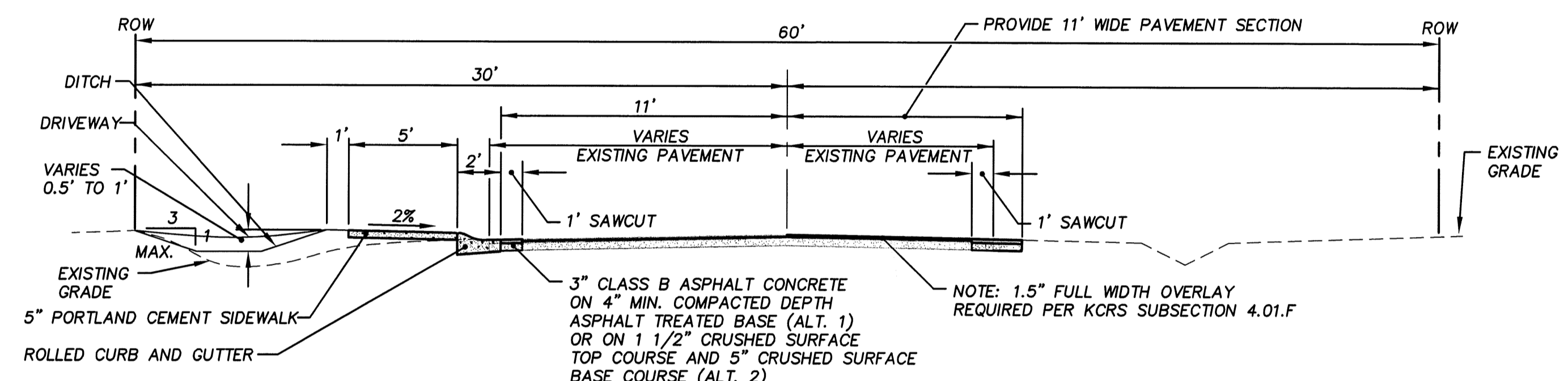

**SUBCOLLECTOR URBAN - SECTION F-F**  
55TH AVE S STA. 53+58.01 TO STA. 59+25.84

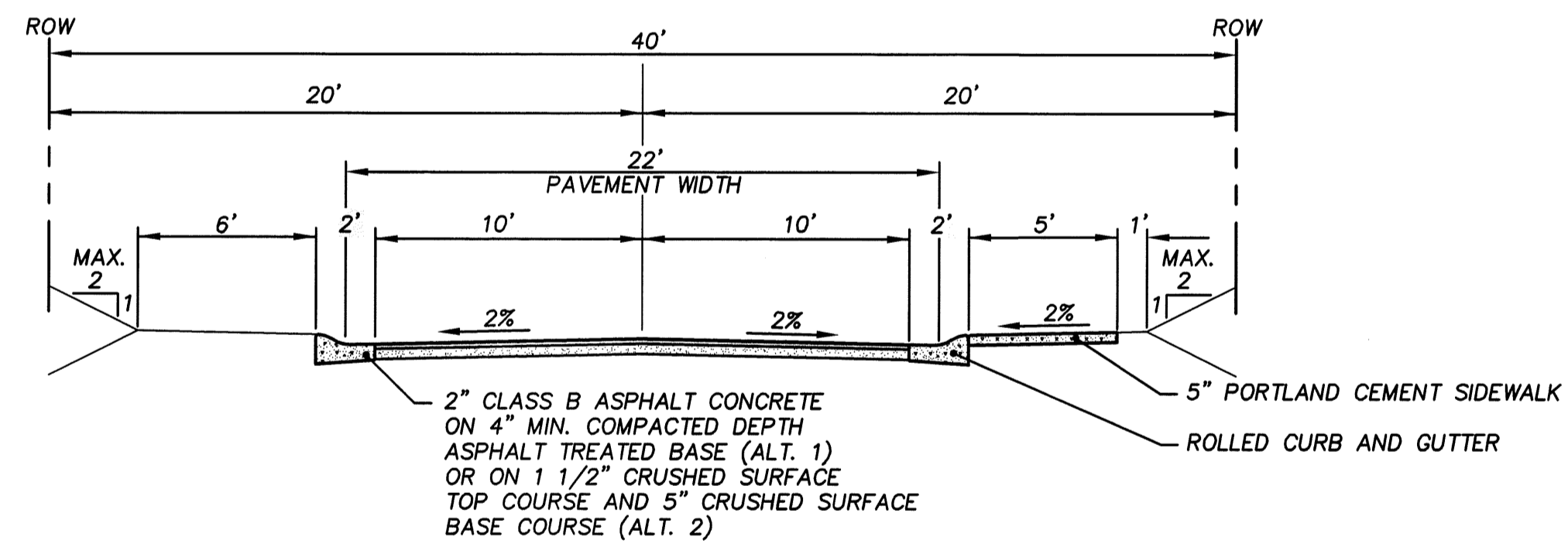

**MINOR ACCESS STREETS URBAN SECTION C-C**  
57TH CT S. 1+22.20 TO 2+37.89

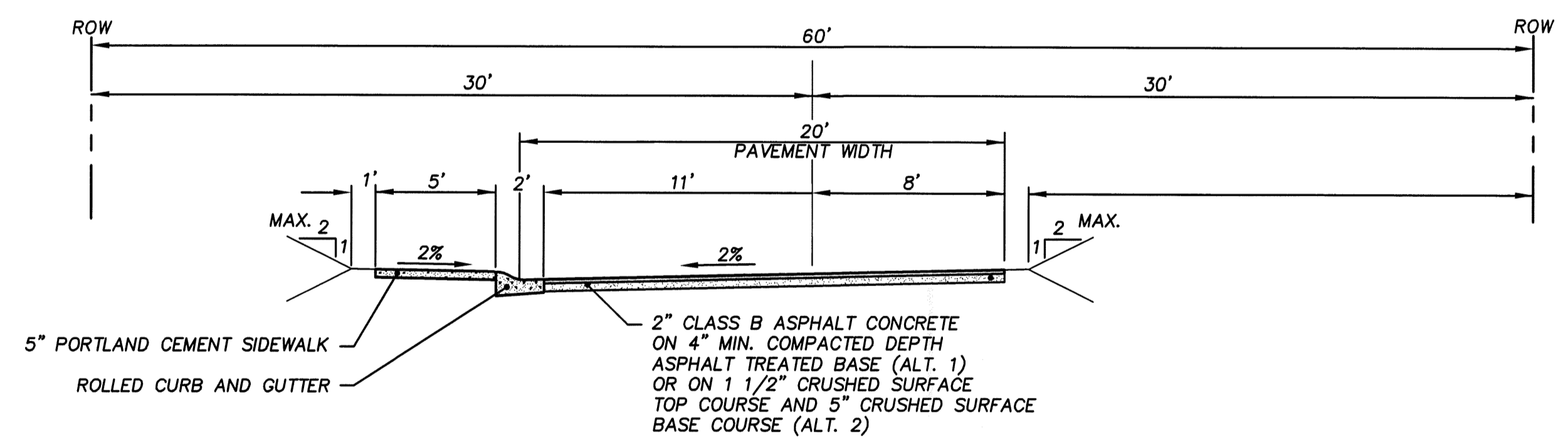

**SUBACCESS URBAN - HALF STREET LEFT SECTION G-G**  
57TH AVE S STA. 15+40.91 TO STA. 17+32.34

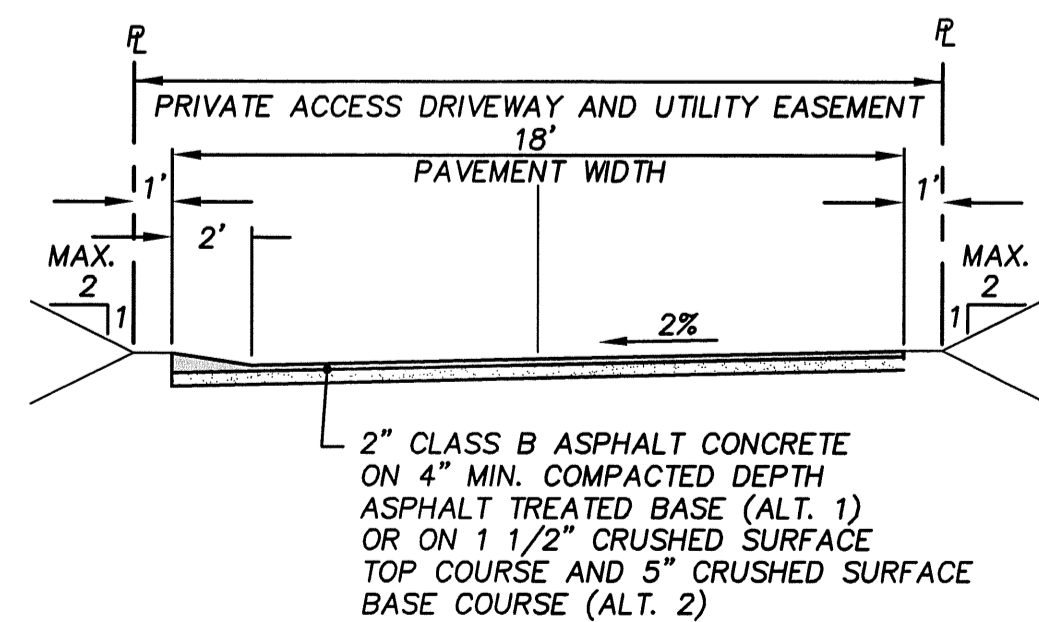

**JOINT-USE DRIVEWAY AND UTILITY EASEMENT SECTION D-D**  
TO LOTS 11, 14, 17, 20, 22, 24, 26, 28, 35, AND 36

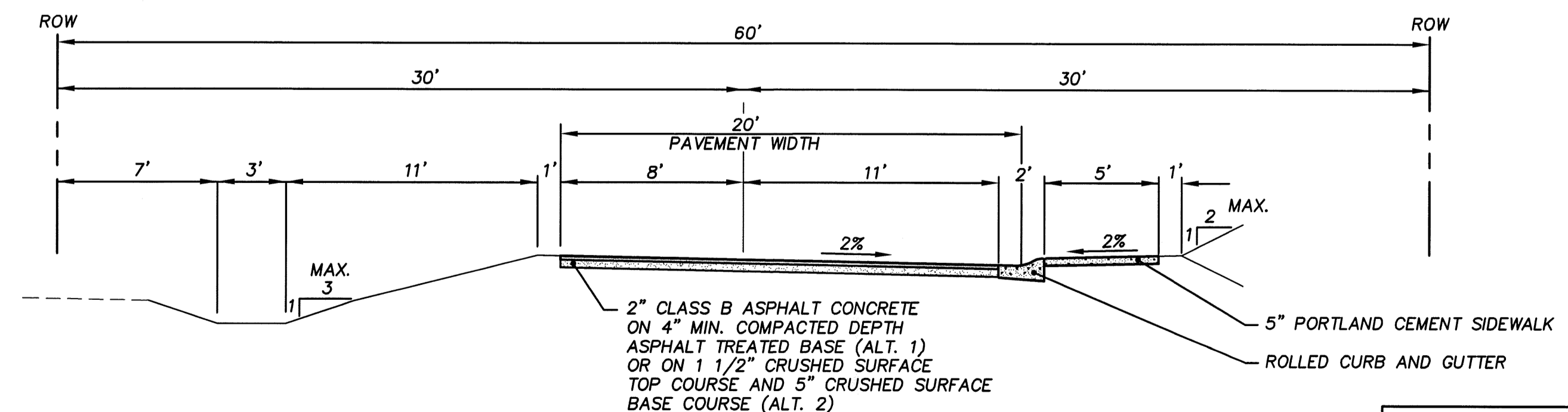

**SUBACCESS URBAN - HALF STREET RIGHT SECTION H-H**  
55TH AVE S STA. 50+37.89 TO STA. 52+76.10

KING COUNTY D.D.E.S.	
Review Engineer	Completion Date
Senior Engineer	Completion Date
MOLLY A. JOHNSON, P.E. DEVELOPMENT ENGINEER	Approval Date
Comments:	